

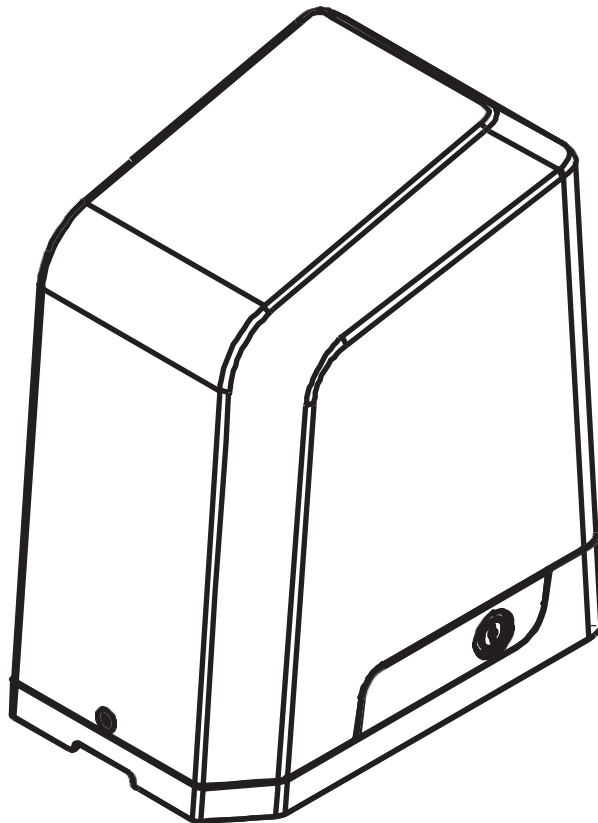

GTR510 SLIDING GATE MOTOR

User Manual



INDEX

1. WARNINGS	1
2. INSTALLATION	2
A. STANDARD INSTALLATION DEMONSTRATION	2
B. DESCRIPTION OF DEVICE	2
C. DIMENSION OF DEVICE	3
D. INSTALLATION OF MOTOR GEAR AND GEAR RACK	3
E. CHECKING FOR INSTALLATION	4
F. EMERGENCY RELEASE	4
3. SETUP AND FUNCTION SETTING	5
A. WIRE CONNECTION	5
B. TRANSMITTER MEMORIZATION AND ERASING PROCESS	6
C. SYSTEM LEARNING, RESET PROCESS AND LED DISPLAY	6
D. HOW TO SET THE PARAMETER	7
E. PROGRAMMABLE FUNCTION SETTINGS	7
F. RECOGNITION OF LED	10
4. Technical Characteristics	10
A. TECHNICAL DATA SHEET OF SERIES	10

1. GENERAL PRECAUTION:

WARNING :

This user manual is only for qualified technicians who is specialized in installations and automations.

- (1) All installations, electrical connections, adjustments and testing must be performed only after reading and understanding of all instructions carefully.
- (2) Before carrying out any installation or maintenance operation, disconnect the electrical power supply by turning off the magneto thermic switch connected upstream and apply the hazard area notice required by applicable regulations
- (3) Make sure the existing structure is up to standard in terms of strength and stability
- (4) When necessary, connect the motorized gate to reliable earth system during electricity connection phase.
- (5) Installation requires qualified personnel with mechanical and electrical skills.
- (6) Keep the automatic controls (remote, push bottom, key selectors...etc) being placed properly and away from children.
- (7) For replace or repair of the motorized system, only original parts must be applied. Any damage caused by inadequate parts and methods will not be claimed to motor manufacturer.
- (8) Never operate the drive if you have any suspect with what it might be faulty or damage to the system.
- (9) The motors are exclusively designed for the gate opening and closing application, any other usage is deemed inappropriate. The manufacture should not be liable for any damage resulting from the improper use. Improper usage should void all warranty, and the user accepts sole responsibility for any risks there

Technical Support

For support or assistance with installing your gate motor, visit gatesupport.richmondau.com

Or ring your local Richmond Wheel & Castor Branch

AU: 1300 474 246 **NZ:** 0800 61 71 81 **International:** +613 9551 2233

Richmond Wheel & Castor Co. declines all responsibility for any consequences resulting from improper use of the product, or use which is different from the expected and specified in the present documentation.

Richmond Wheel & Castor Co. declines all responsibility for any consequences resulting from failure to observe Good Technical Practice when constructing closing structures (door, gates etc), as well as from any deformation which might occur during use.

2. INSTALLATION:

A STANDARD INSTALLATION DEMONSTRATION

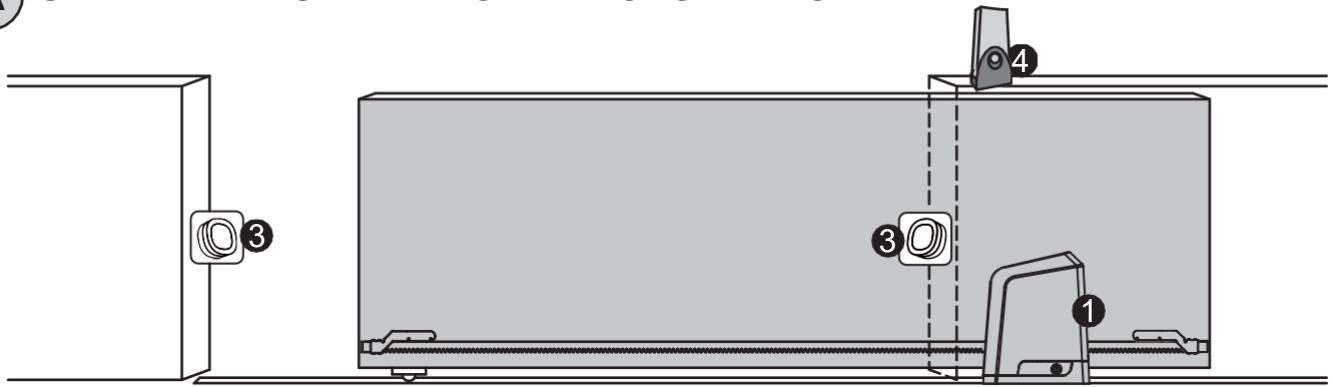

1. 24Vdc sliding motor
2. Transmitter
3. Safety photo sensor
4. Flashing light

B DESCRIPTION OF DEVICE

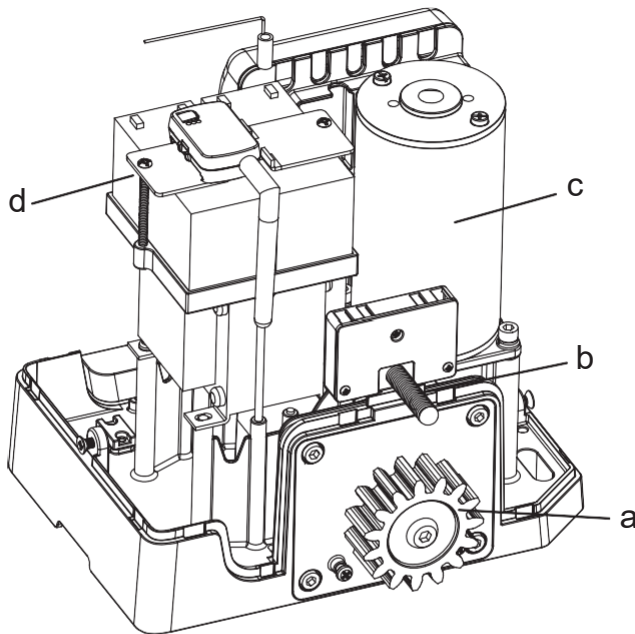

- a. Operation gear
- b. Limit switch device
- c. 24Vdc motor
- d. Back-up batteries (Optional)

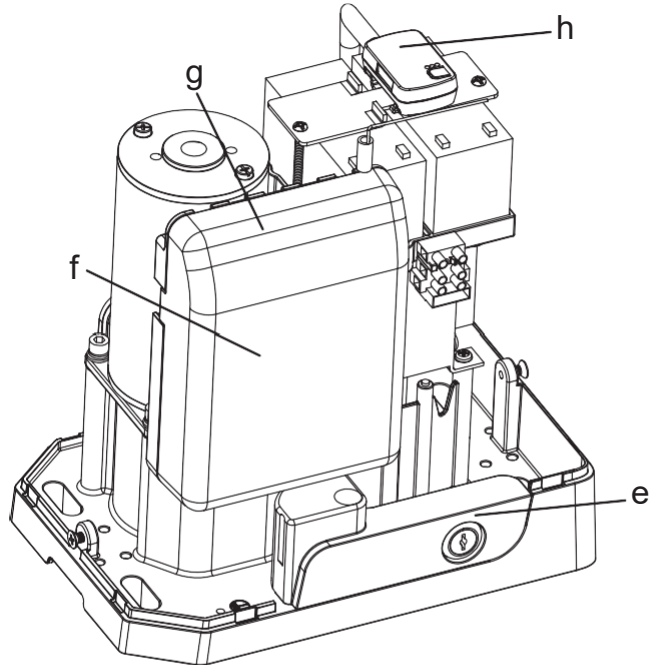

- e. Release device
- f. Control panel under the cover
- g. Cover of the control panel
- h. Wifi Box (Refer to WB2 User Manual)

C DIMENSION OF DEVICE

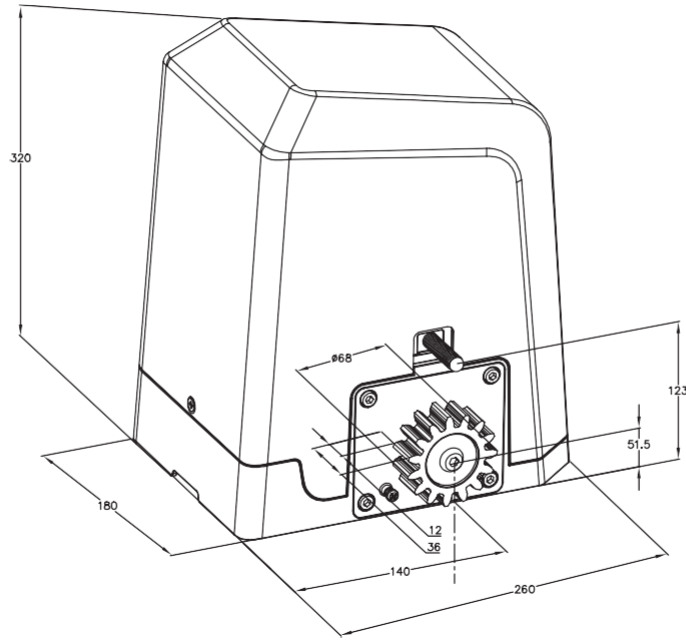

D INSTALLATION OF MOTOR GEAR AND GEAR RACK

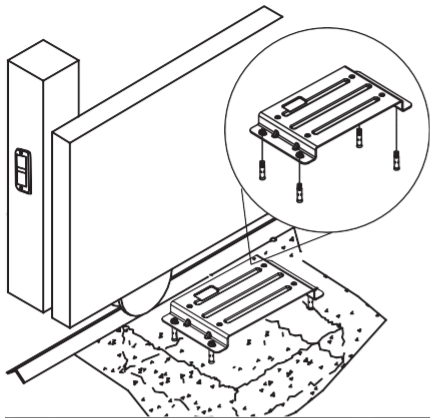

Place the first rack on the driving pinion and trace the drilling locations completely. The rack must be perfectly horizontal. Mark a trait on the top of rack.

Proceed in this way over the entire length of the gate. **(Figure 2)**

Note: Help yourself to use one piece of rack to stabilize 2 pieces of racks.

(Figure 3)

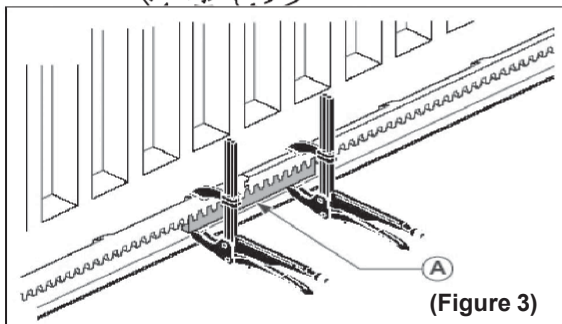

(Figure 3)

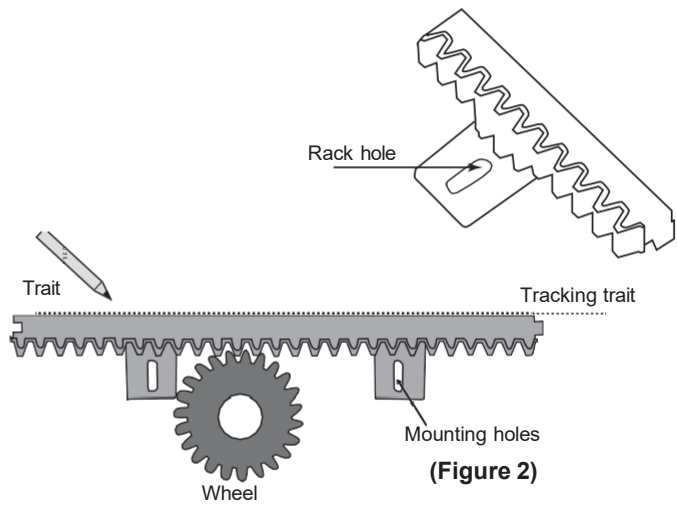

(Figure 2)

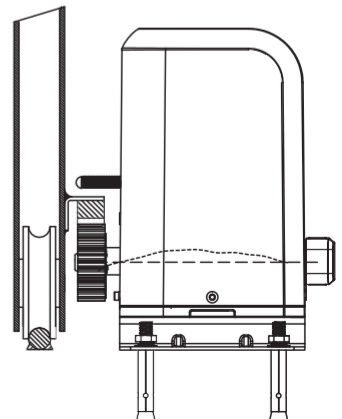
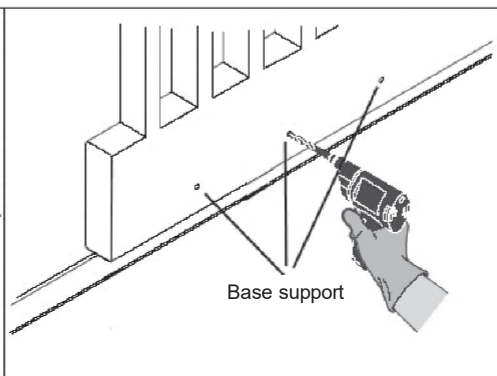
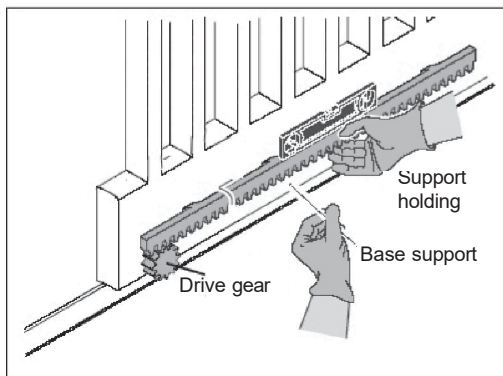

E CHECKING FOR INSTALLATION

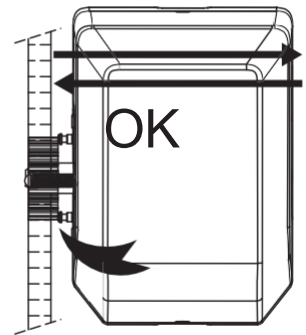
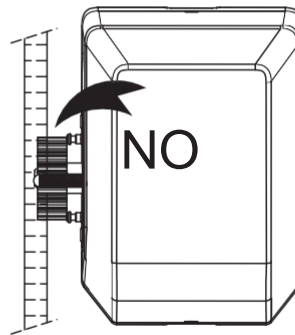
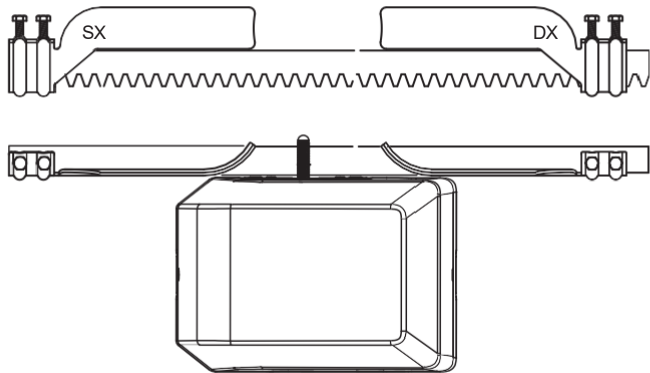

F EMERGENCY RELEASE

In the case of power failure for emergency release of the motor, please follow the procedure as below:

Step1 & Step2. Insert the key and turn clockwise to unlock the device.

Step3. Pull the release bar.

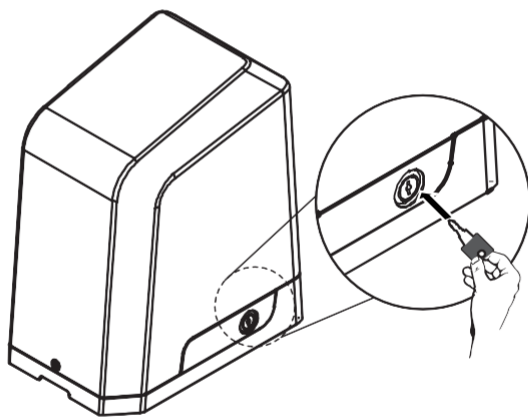
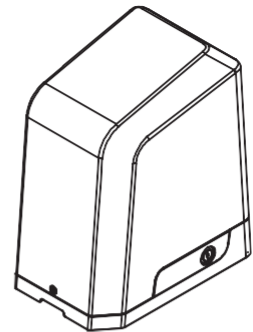

Step1

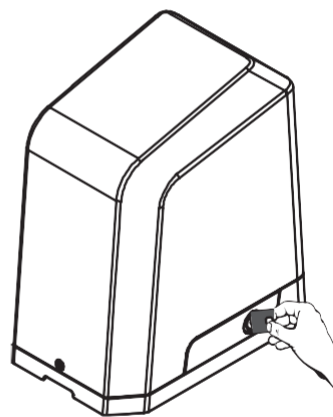

Step2

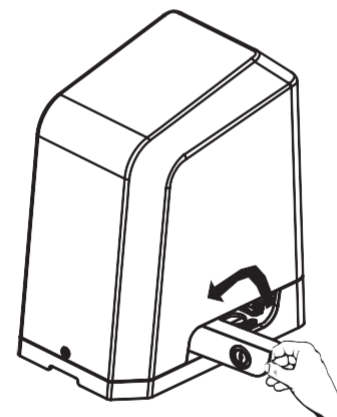

Step3

3. SETUP AND FUNCTION SETTING

A WIRE CONNECTION

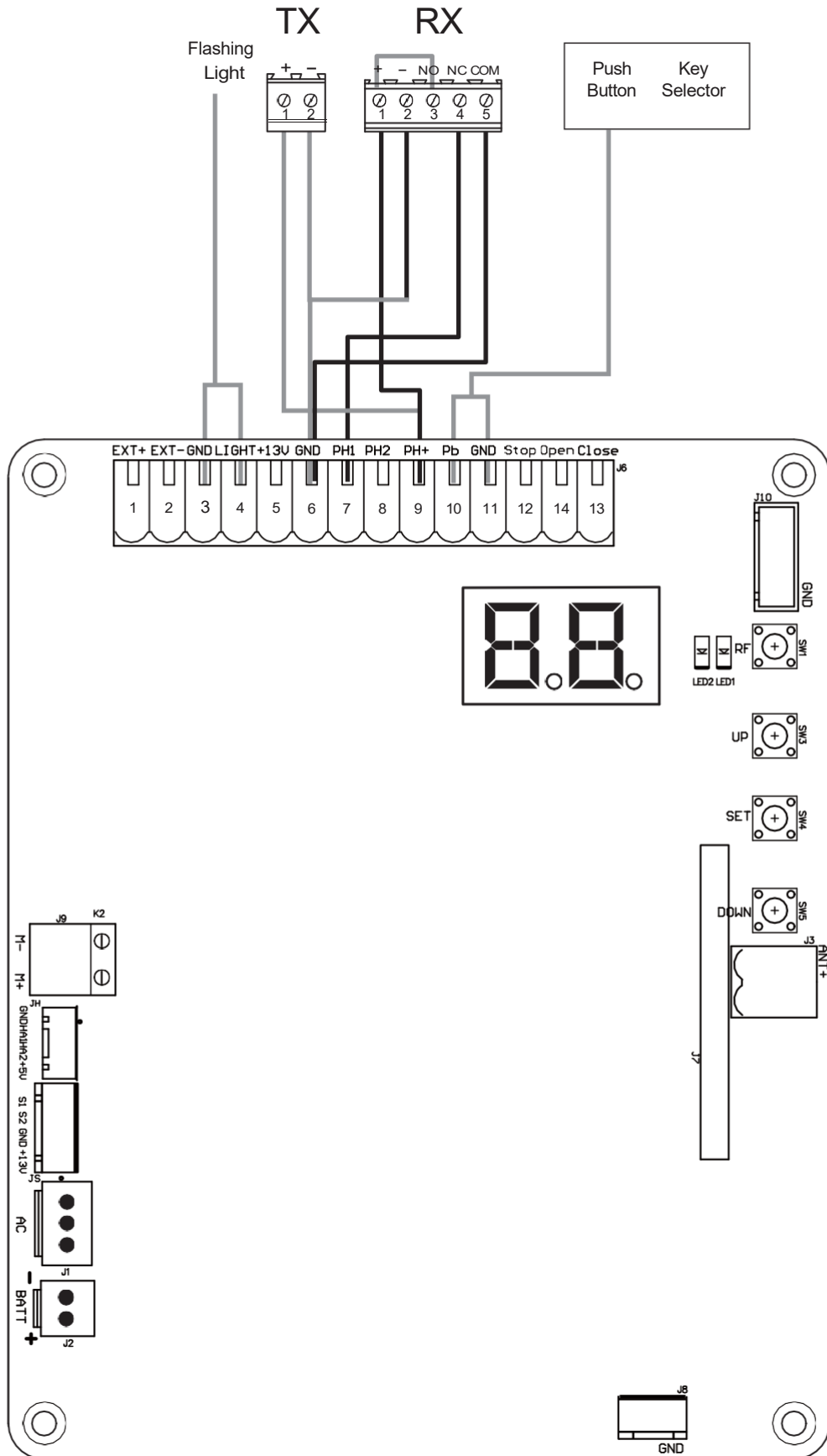

B TRANSMITTER MEMORIZING AND ERASING PROCESS

(1) Transmitter Memorizing: Press "RF Learn" button for 3 seconds, and the LED display shows "CS"; then press the transmitter left button (A); the LED display will blink three times and stay on, and after 7 seconds without any new remote learn then the LED will be off. The transmitter learning is completed. **1 2 3**

(2) Erasing Memory: Press "RF Learn" button for 10 seconds as right LED display shows "CC", then all the memory will be deleted.

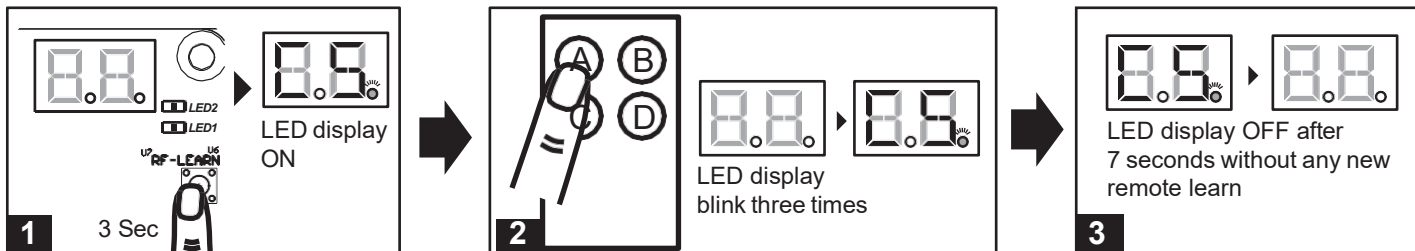

C SYSTEM LEARNING, RESET PROCESS, AND LED DISPLAY

! CAUTION: Before proceeding to system learning, the transmitter memorizing process has to be completed.

(1) To Complete the System Learning:

Step1: Press "SET"; then press "SET" + "DOWN" for 3 seconds, and the LED display shows "LE" **1 2 3**

Step2: Press left button (A) on time, the LED display should show "LP" **4 5**

Step3: The gate goes to Auto-learning, please wait for the learning process to be completed **6**

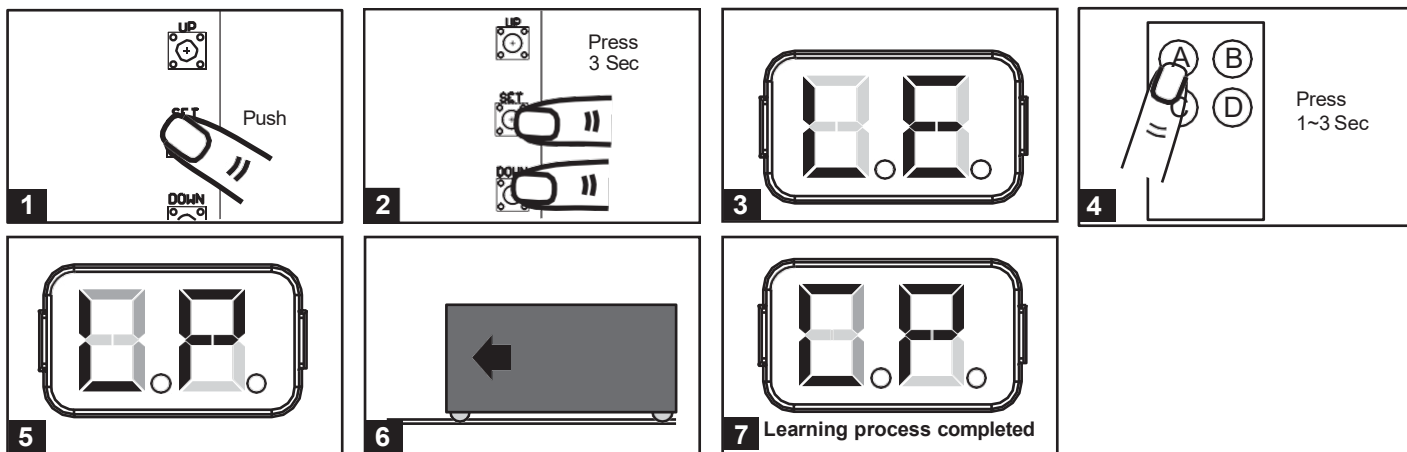

(2) To Reset Factory Setting:

Press UP and DOWN for 3 seconds, and the LED display shows "CL"

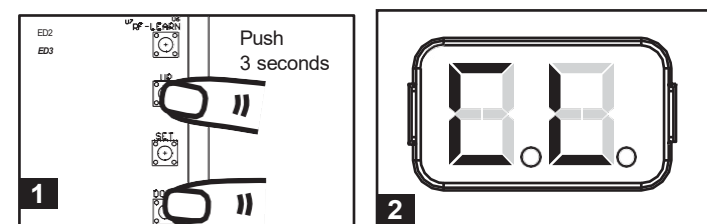

(3) Motor current auto-detection

The LED display shows the current consumption of the motor

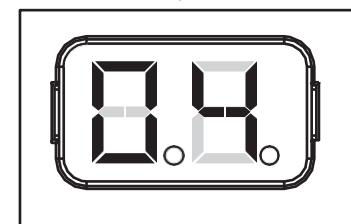

"0.4" : During the system learning procedure, the control panel will automatically detect the current consumption from each motor, indicate the resistance level of the gate while the motor operation. If this reading increase instantly or stay in high reading, please check if any object in between of the gate moving area, and contact your installer for inspection.

LED Display	Programmable Functions	LED Display	Programmable Functions
	"L": The system learning is not done.		"LE": Enter learning mode and then wait for learning instructions.
	"OP": The system is in normal operation To program, press SET button for 3 seconds, when the LED display change from OP to 1, press UP or DOWN to change function settings (1 to P). Then press SET to enter the sub function within each group, press UP or Down to select sub functions and press SET for confirmation.		"LP": The system learning is in progress. The Auto-learning process of gate moving: "Gate open to the end- stop close to the end- stop."
	"CP": system learning completed.		"CL": Reset Factory Setting.

D HOW TO SET THE PARAMETER:

Step 1: Press the "Set" key for 3 seconds, the display will show the function code.

Step 2: Choosing the setting by Up and Down keys, after having chosen the indicated item, press the Set key and enter the setting of this function. The second digit will be shown on the right of the display, indicating the related function (please refer below chart for details). Using the Up and the Down Keys to choose the setting function and press the Set key to save.

E PROGRAMMABLE FUNCTION SETTINGS

LED	Definition	Function	Value	Description
1	Operation Direction	11 12	Open to the left (Default) Open to the right	1. The function can adjust the direction of gate opening. 2. The default setting is "11".
2	Auto-Closing	20 21 22 23 24 25 26 27 28	No auto close (Default) 5 seconds 15 seconds 30 seconds 45 seconds 60 seconds 80 seconds 120 seconds 180 seconds	1. The function can be used to close the gate automatically after the paused time. 2. The default setting is "20": No auto closing time. 3. Auto-closing function can be deactivated by long pressing "F.F feature (please refer to the last parameter setup)" key for two sec. The gate will slide to fully open position and all the operations will be locked until long press the "F.F feature" key for 2 sec again to re-activate the auto-closing function again.
3	Safety Device Function Mode	31 32 33	Mode 1 (Default) Mode 2 Mode 3	1. Please do the function setting after H & J 2. The default setting is "31". 3. Please refer to F3 function settings at page 9
4	opening operation speed	41 42 43 44	50% operating speed, 50% learning speed 70% operating speed, 50% learning speed 85% operating speed, 50% learning speed 100% operating speed, 50% learning speed (Default)	1. The function can adjust the running speed of motor. 2. The default setting is "44". Motor operation from deceleration zone: the motor will follow the learning speed until it touch the limit switch Motor operation from other zone: The motor will cost 1 sec from stop to full speed and it will stop till it approaches the limit switch.
5	closing operation speed	51 52 53 54	50% operating speed, 50% learning speed 70% operating speed, 50% learning speed 85% operating speed, 50% learning speed 100% operating speed, 50% learning speed (Default)	1. The function can adjust the running speed of motor. 2. The default setting is "54". Motor operation from deceleration zone: the motor will follow the learning speed until it touch the limit switch Motor operation from other zone: The motor will cost 1 sec from stop to full speed and it will stop till it approaches the limit switch.
6	Deceleration point	61 62 63 64 65	75% 80% 85% 90% (Default) 95%	1. The default setting is "64"
7	Deceleration speed	71 72 73 74	20% 30% 40% (Default) 50%	1. The default setting is "73"

LED	Definition	Function	Value	Description
8	Opening Overcurrent Setting	81 82 83 84 85 86 87 88 89 8A	4A 5A 6A 7A 8A 9A 10A (Default) 11A 12A 13A	<p>1. The function can adjust the running force of motor to be compatible with the gate weight.</p> <p>2. The default setting is "87".</p> <p>WARNING: The maximum overcurrent for 500kg motor is 10A, it may have the potential risk if the adjustment over 10A current.</p>
9	Closing Overcurrent Setting	91 92 93 94 95 96 97 98 99 9A	4A 5A 6A 7A 8A 9A 10A (Default) 11A 12A 13A	<p>1. The function can adjust the running force of motor to be compatible with the gate weight.</p> <p>2. The default setting is "97".</p> <p>WARNING: The maximum overcurrent for 500kg motor is 10A, it may have the potential risk if the adjustment over 10A current.</p>
A	Pedestrian Mode	A0 A1 A2 A3 A4 A5 A6	OFF (Default) 3seconds 6seconds 9seconds 12seconds 15seconds 18seconds	<p>1. The function can adjust the time of opening partially.</p> <p>2. The default setting is "A0".</p>
C	Flashing Light If the motor stop by over current or limit switch, the flashing light will keep blinking for 1 minute	C0 C1 C2	The motor and flashing light will operate at the same time Followed with FC-0, the flashing light will keep blinking for 1 minute after the motor stop Followed with FC-0, the flashing light will keep blinking for 10 minutes after the motor stop	<p>1. The default setting is "C0".</p>
E	Over Current Reaction	E0 E1 E2 E3	Stop Reverse 1 second and stop Reverse 3 seconds and stop Reverse to the end (Default)	<p>1. The default setting is "E3".</p> <p>2. The reverse function only operates 3 times and stops.</p> <p>3. If gate reverses, the auto-closing function will be cancelled.</p>
F	Main Operation Key	F1 F2 F3 F4	A key (Default) B key C key D key	<p>1. The default setting is "F1".</p>
H	Pedestrian function	H0 H1 H2 H3 H4	No function (Default) A key B key C key D key	<p>1. The default setting is "H0".</p>
J	External Device Key	J0 J1 J2 J3 J4	No function (Default) A key B key C key D key	<p>1. The default setting is "J0".</p>
L	Photocell 1 Activation	L0 L1	Function OFF (Default) Function ON	<p>1. The default setting is "L0".</p>

LED	Definition	Function	Value	Description
P	Photocell 2 Activation	P0 P1	Function OFF (Default) Function ON	1.The default setting is "P0".
U	PCB Stop Terminal Activation	U0 U1	Function OFF (Default) Function ON	1. The default setting is "U0".
A	Pb Terminal Function	A.1 A.2 A.3 A.4	Open-Stop-Close-Stop (Default) Open Only Pedestrian Mode Fire Alarm Mode	1. The default setting is "A.1" 2. Fire Alarm Mode: * Terminal Detect NO - normal operation * Terminal Detect NC - Open the gate and lock all the functions before return to NO
C	Open Terminal Function	C.1 C.2 C.3 C.4	Open-Stop-Close-Stop Open Only (Default) Pedestrian Mode Fire Alarm Mode	1. The default setting is "C.2" 2. Fire Alarm Mode: * Terminal Detect NO - normal operation * Terminal Detect NC - Open the gate and lock all the functions before return to NO
E	Overcurrent Sensitivity Setting	E.1 E.2 E.3 E.4 E.5 E.6 E.7 E.8 E.9 E.A	0.1 sec 0.2 sec 0.3 sec 0.4 sec 0.5 sec (Default) 0.6 sec 0.7 sec 0.8 sec 0.9 sec 1 sec	1. The default setting is "E.5".
F	Deactivate Auto-Closing Feature	F.0 F.1 F.2 F.3 F.4	No function (Default) A key B key C key D key	1. Default setting "F.0". 2. This feature requires a 2-second long press to activate. 3. When F2 is set as F20 (No auto-closing), this feature is recommended to be set as F.0 (no function) as well.

● F3 function settings:

Logic F3-1 The reactions of the photocells when detecting obstacles

Gate Status	Photocell 2	Photocell 1
Closed	Open not allowed	No effect
Open	No effect	Reloads automatic closing time
Stop during moving	Open not allowed	Reloads automatic closing time
Closing	No effect	Open
Opening	Close	No effect

Logic F3-2 The reactions of the safety edge/ photocell when detecting obstacles

Gate Status	Safety Edge	Photocell 1
Closed	Open not allowed	No effect
Open	Reloads automatic closing time	
Stop during moving	Open/Close not allow	Reloads automatic closing time
Closing	Reverses to open for 2 seconds	Open
Opening	Reverses to close for 2 seconds	No effect

Logic F3-3 The reactions of the loop detector/ photocell when detecting obstacles

Gate Status	Loop Detector	Photocell 1
Closed	Open	No effect
Open	Reloads automatic closing time	
Stop during moving	Open	Reloads automatic closing time
Closing	Open	Open
Opening	No effect	No effect

● The position of safety devices:

- Safety Edge
- Photocell

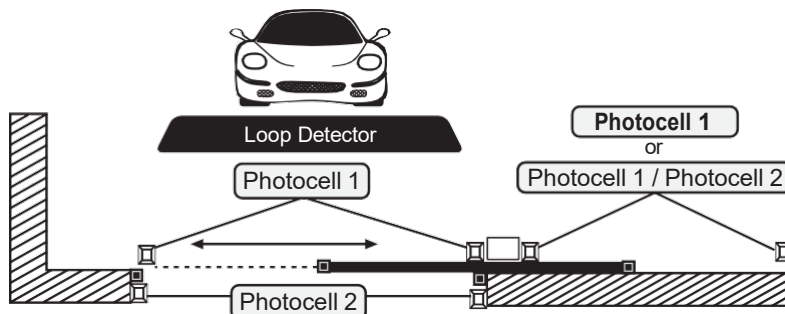

Testing And Checking

Make sure the notices included in 1.1 General safety precaution “WARNINGS” has been carefully observed.

- Release the gear motor with the proper release key.
- Make sure the gate can be moved manually during opening and closing phases with a force of max. 390N (40 kg approx.)
- Lock the gear motor.
- Using the Key selector switch, push button device or the radio transmitter, test the opening, closing and stopping of the gate and make sure that the gate is in the intended direction.
- Check the devices one by one (photocells, flashing light, key selector, etc.) and confirm the control unit recognizes each device.

F RECOGNITION OF LED

LED Indication	Descriptions
LED1 Photocells Indicator	LED1 will be on when the first pair of the photocells are activated.
LED2 Photocells Indicator	LED2 will be on when the second pair of the photocells are activated.

4. Technical Characteristics:

A TECHNICAL DATA SHEET OF SERIES

Motor	GTR510
Thrust	8000N
Motor RPM	3600RPM
Wattage	144W
Voltage	24Vdc
Current	6A
Maximum gate weight	800KG
Maximum gate length	8M
Duty cycle	20%
Temperature	-20°C~+50°C
Dimension LxWxH mm	260*180*318mm
Speed	25.67 cm/s