

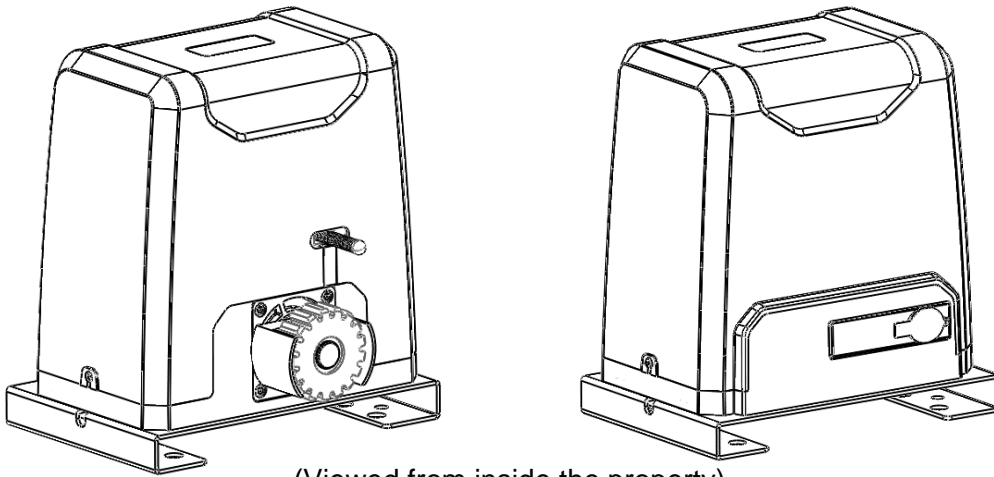

Sliding Gate Opener User Manual

Model: GTR156

Please Note: This motor is AC 240V Power only and is not compatible with DC Battery Backup or Solar power.



(Viewed from inside the property)

TECHNICAL SUPPORT

Instructions must be read before beginning installation. Please follow these instructions carefully, incorrect installation could affect gate operation. If you require more information, please contact your local Richmond Wheel & Castor Co branch

For installation or troubleshooting assistance visit richmondau.com/gate-motor-support/

AU: 03 9070 5713 **NZ:** 0800 61 71 81 **International:** +613 9551 2233

Thank you for choosing this sliding gate opener.
Please read the manual carefully before installation.
Do not exclude this manual if you send this product to a third party.
This product complies with the recognised technical standards and safety regulations.
Our company has the right to change this manual without prior notice.

General Safety:

Warning: Incorrect or improper use of this product can cause damage to persons, animals or properties.

- Please ensure that the input voltage used matches with the supply voltage of gate opener (AC240V 50Hz).
- All modifications to wiring or electrics, and any adjustment or maintenance to 240VAC **MUST** be done by a qualified electrician.
- To avoid damaging gas, power or other underground utility lines, contact the relevant authority **BEFORE** digging.
- All potential hazards and exposed pinch points of the gate must be eliminated or guarded prior to installation of this gate motor.
- Never mount any device that operates the gate motor where the user can reach over, under, around or through the gate to operate the controls. These must be placed at least 1.8m from any moving part of the moving gate.
- Ensure power plug is disconnected from the power socket during installation or maintenance.
- Keep remote control and other control devices out of children's reach, in order to avoid unintentional activation.
- Never allow anyone to hang onto the gate while moving.
- Please ensure a warning sign provided is fitted to the structure.
- To ensure safety, before installing the main motor, mount a Gate End Stop (GTR017) and a Gate Stopper (GTR017 or GTR018) at each end of the rail to prevent the gate travelling off the track.
- If required, install infrared photocells (GTR051, sold separately) to detect obstructions and prevent injury or damage.
- Instruct all users about the control systems provided and the manual opening operation in case of emergency.
- Ensure that the power cable is connected to a RCD protected weatherproof power outlet installed by a qualified electrician.
- Do not install the product in an explosive atmosphere or where there is any danger of flooding.
- This product was exclusively designed and manufactured for the use specified in the present documentation. Any other use not specified in this documentation could damage the product and be dangerous.
- Only use original parts for any maintenance or repair operation. Richmond Wheel & Castor Co declines all responsibility with respect to the automation safety and correct operation when other supplier's components are used.
- Do not modify the automation components, unless explicitly authorised by Richmond Wheel & Castor Co.
- The user must avoid any attempt to carry out any works or repairs on the motor and should always request the assistance of qualified personnel.
- This motor is suitable for use on one sliding gate only.
- Anything which is not expressly provided for in these instructions is not allowed and will void warranty.
- Dispose of all packing materials (plastic, cardboard, polystyrene etc.) according to current guidelines. Keep plastic bags and polystyrene out of children's reach.
- Save these instructions for future use

Contents:

General Safety	2
Gate Opening Default Setting Information	4
Parts List	6
Technical Specifications	7
Motor Installation	
Before you start.....	8
Tools Required / Example Sliding Gate Setup.....	9
Step 1 - Gate Preparation Before Adding Your Motor	10
Step 2 – Motor Pad Footing.....	10
Step 3 - Motor Position Installation.....	11
Step 4 – Removing Motor Cover for Mounting.....	12
Step 5 – Drilling Holes for Anchor Bolts.....	12
Step 6 – Fitting the Mounting Plate & Motor.....	13
Step 7 – Gear Rack & Motor Alignment.....	14
Step 8 – Limit Travel Stops.....	16
Step 9 – Powering the Motor.....	18
Step 10 – Testing the Limit Travel Stops.....	19
Programming and Wiring	
Control Board Diagrams.....	20
Dip Switch Adjustment.....	22
Further Settings and Programming.....	23
Adding optional automatic functions to your gate	
Automatic close function	22
Adding a keypad (sold separately).....	22,24
Adding an entry/exit wand (sold separately).....	24
Maintenance	26
Troubleshooting	27
Pairing and Clearing Remotes	28
Additional Drawings and Diagrams	29

Gate Opening Default Setting Information:

The gate motor will open the gate to the right-hand side as its default setting (refer to fig 1).

It is recommended that you allow a minimum 500mm bottom rail extension from your inside gate post opening. This will enable you to have enough room to secure your gear rack and placement for the motor.

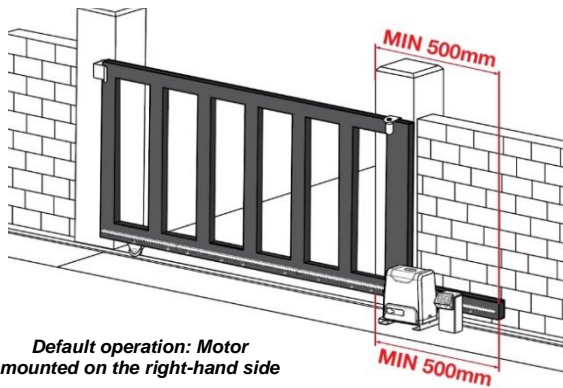

Default operation: Motor mounted on the right-hand side

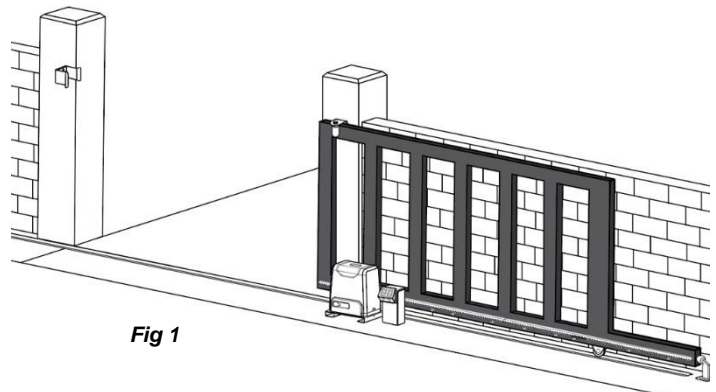
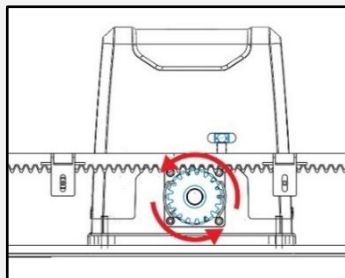

Fig 1

Before Installing: Test the motor by plugging it into a power source and pressing the remote. You will see the motor cog turn. When it stops, press the remote again to see it turn in the opposite direction. This will give you an understanding of the way in which the motor will move the gate.



Press the first/top button on the remote.



The motor cog will turn counter-clockwise, moving the gate frame.

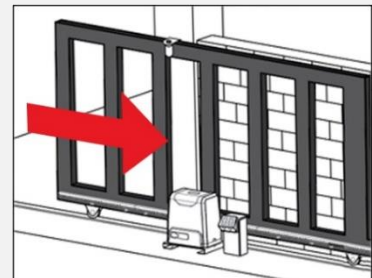

The gate will then move in the set direction. Default: right-hand open.

Note: Ensure that the motor is unplugged before proceeding with installation. Please keep fingers away from the motor cog whilst it is turning.

If your gate needs to open from the other direction (to the left, refer to fig 2) your motor needs to be mounted on the left hand side as shown, and a qualified electrician will need to swap over the MOT1 and MOT2 lines on terminal J4 (refer to pages 20 and 21) and swap over lines 11 & 13 on terminal J5 (refer to page 20).

It is recommended that you allow a minimum 500mm bottom rail extension from your inside gate post opening. This will enable you to have enough room to secure your gear rack and placement for the motor.

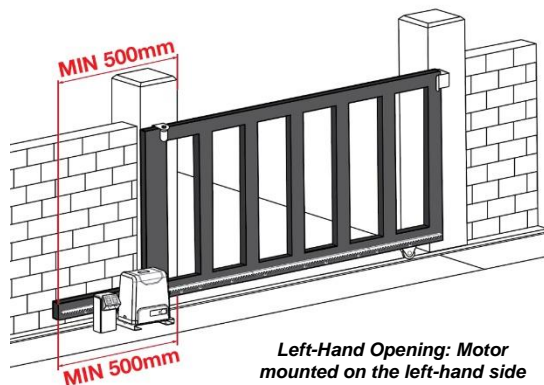

Left-Hand Opening: Motor mounted on the left-hand side

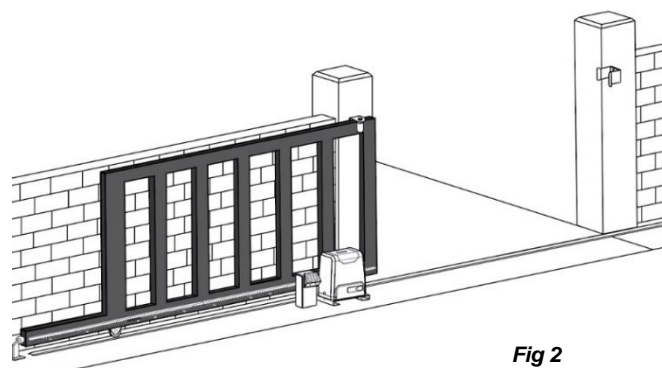





Fig 2

Any works done to the motor must be completed whilst the power is off, and the motor is unplugged

Parts List:

No.	Picture	Name	Quantity
1		Main motor	1
2		Motor Mounting Plate	1
3		Manual release keys (These keys are needed during power outage, keep on hand)	2
4		Remote controls (factory paired to motor)	2
5		Gate Warning Signage (must be fitted to gate)	1
6		In the accessories box you will find the items below:	1
6a		Limit travel stops (left hand & right hand)	2
6b		Limit travel stop mounting screw M6x18	4
6c		Masonry Anchor bolt M12x100mm (Drill bit size: M12 Masonry)	4
6d		Motor mounting set screws M10 x 50mm, spring & flat washers	4

Technical Specifications:

Model	GTR156
Power supply	240VAC/50Hz
Motor power	400W
Gate moving speed	11-13m/min
Maximum weight of gate	1200Kg
Maximum length of gate	12m
Remote control distance	Up to 30m
Remote control mode	Single Button Mode
Limit switch	Spring Limit Switch
Noise	Up to 60dB
Working duty	S2 - 20min (20 minutes maximum continuous operation)
IP Rating	IP54
Maximum # Remote Controls	25
Remote Control Frequency	433.92 MHz
Working temperature	-20°C ~ +70°C
Package weight	15Kg

1. Open/Close

Press the button for standard gate opening and closing operation.



4. Pedestrian Mode

Press the button while the gate is closed, the gate will open 1m wide to allow pedestrian access. Press the remote again to close.

Motor Installation:

Before you start:

- The GTR156 Sliding Gate Automation Kit is suitable for powering the opening and closing motion of gates up to 1200kg in weight, up to a length of 12m.
- Gate motion is achieved by the rotating cog of the gate motor driving the gear rack fitted to the moving gate (GTR092, sold separately).
- The gate motor requires you to press the remote control once to open, and once again to close. This is a safety feature to ensure safe operation.
- The gate motor itself must be fitted within private property, never externally to a property's boundary.

Power Supply: The GTR156 requires 1 x 10Amp AC240V 50Hz power supply (RCD Protected Weatherproof PowerPoint). The GTR156 comes complete with a power lead and plug that is 1m long. If you do not have a suitable RCD protected weatherproof power point within 1m of the gate motor you will need to consult a licenced electrician.

Any works done to the motor must be completed whilst the power is off and the motor is unplugged.

Any modifications/alterations/works to the 240V AC power components must only be completed by a licensed electrician for your state/country.

Please Note:

Your weatherproof power outlet should be no more than 1m from the electric gate motor.

If your weatherproof power outlet is more than 1m from the gate motor, you will require a licensed electrician to fit a new power cable.

Any excess cable length should be cable tied and secured out of the way of moving objects.



Please Note:

The warning signage provided (Part 5) must be displayed on the street facing side of your automatic gate at all times.

For Installing Your Gate Motor, You Will Need:

- Power drill
- Tape measure
- Level
- 12mm Masonry Drill Bit (for the 4 motor masonry anchor bolts)
- Socket and Spanner Set
- Phillips Head Screwdriver

Example Sliding Gate Setup:

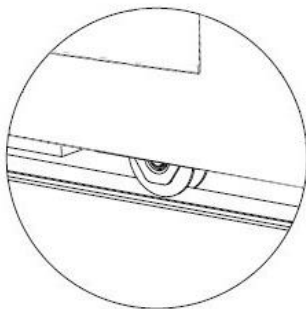
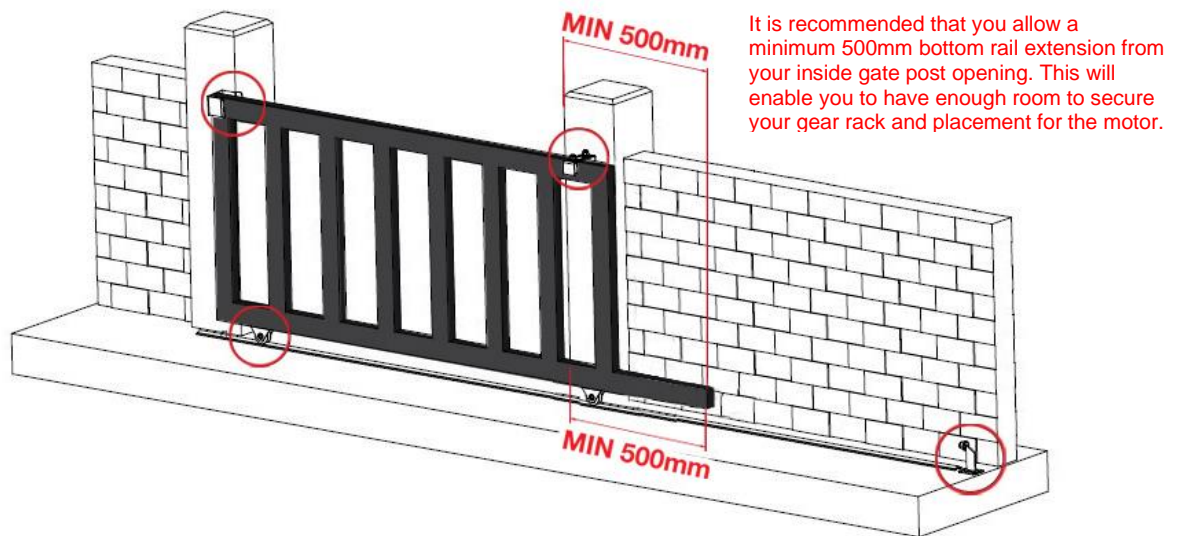

Gate Track and Track Wheels

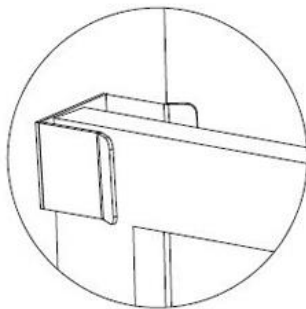

Gate End Catch

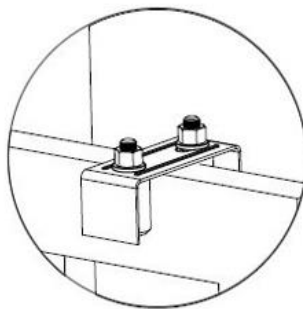

Gate Guide Rollers



Gate Stopper

If you require any gate hardware, contact Richmond Wheel & Castor Co or an authorised reseller.

Please ensure that the motor power cable is not plugged in at any stage before Step 9

Step 1 - Gate Preparation Before Adding Your Sliding Gate Motor:

- Ensure that the sliding gate is correctly installed.
- The gate is horizontal and level and the gate can glide back and forth smoothly when moved by hand before installing the automatic gate opener.
- Wheels and guide rollers should rotate easily and be free from dirt/grime.
- Track should be flat, level and firmly affixed.
- Any misalignment in the gate will affect performance of the automatic gate opener.

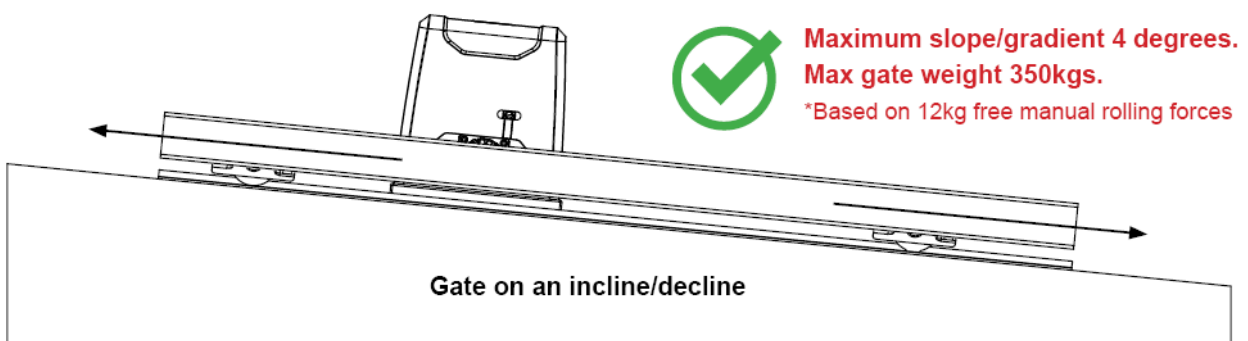
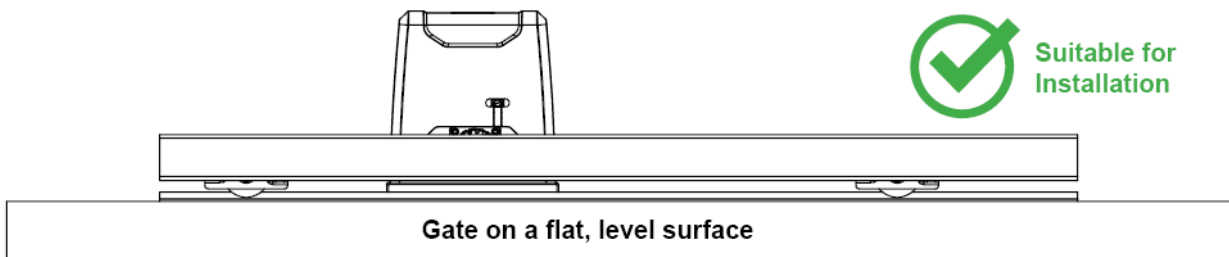
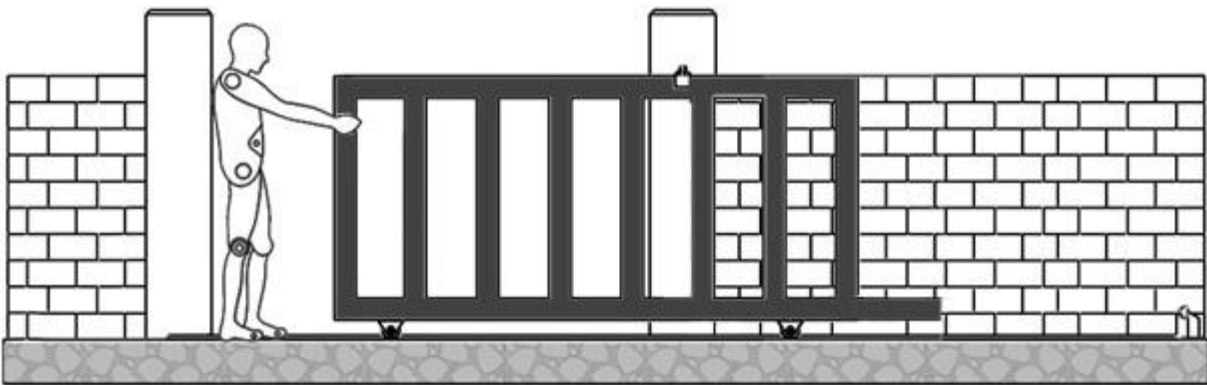

For installation on sloping surfaces contact Richmond for assistance

Step 2 - Motor Pad Footing (Minimum Requirement):

- The motor pad concrete footing requires an area of no less than 450mm long x 300mm wide and a minimum depth of 200mm (Standard requirement).
- Ensure surface is level and parallel to the driveway.
- **Concrete pad should be min 20-25MPA** (Rapid Set Concrete not recommended) allow to cure for 7-10 days before drilling and securing the mounting plate into position.

Mounting Plate Dimensions:

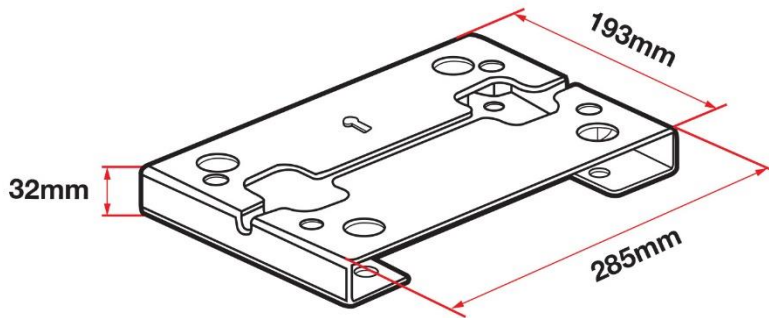

Step 3 - Motor Position Installation:

- Insert the key and open the manual release bar to put the motor into manual mode, and check that the motor cog rotates freely by hand (As per Fig 16).
- Place the motor and motor mounting plate on the concrete pad.
- Make sure the distance between the gate motor cog and gear rack position are aligned (see Fig 4)
- Mark all four outside corners of the mounting plate on the concrete pad using a pencil, chalk or similar, to ensure the mounting plate is in the correct position before drilling.
- Remove motor from the mounting plate.

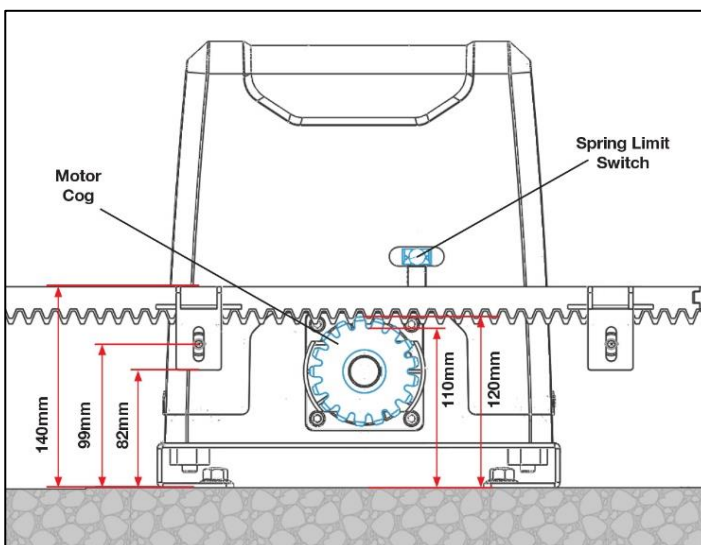

Fig 3

When mounting and positioning the motor ensure that the power cable is unplugged. The motor cover will need to be removed to mount the motor to the mounting plate.

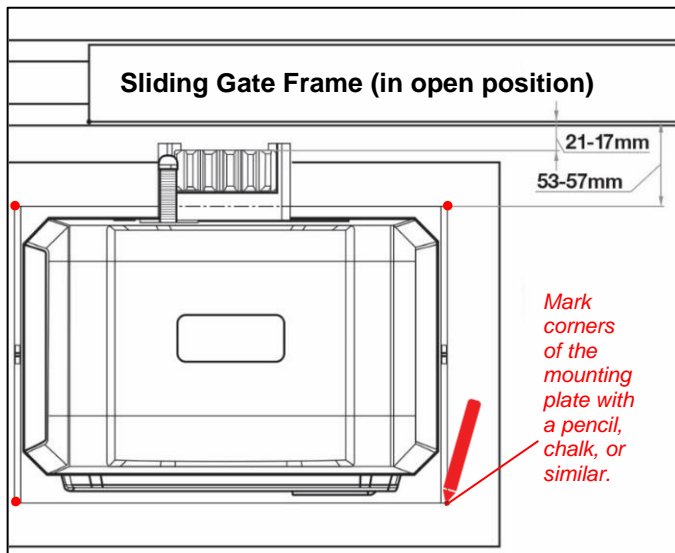

Fig 4

Step 4 – Removing Motor Cover for Mounting:

- Unscrew the two motor cover screws located at each side of the motor cover.
- Remove the rubber grommet below the spring limit switch (as per fig 5).



Fig 5

Please Note: the rubber grommet must be fitted back onto the motor cover once the cover has been re-fitted/replaced onto the base of the motor.

Step 5 - Drilling Holes for Anchor Bolts:

- Ensure the mounting plate is positioned within the marked corners.
- Proceed to mark the (4) positions for your anchor bolts ready for drilling (refer to Fig 6).
- Remove Mounting plate.
- Using a M12 masonry drill bit, drill holes to a minimum depth of 120mm (Fig 7).

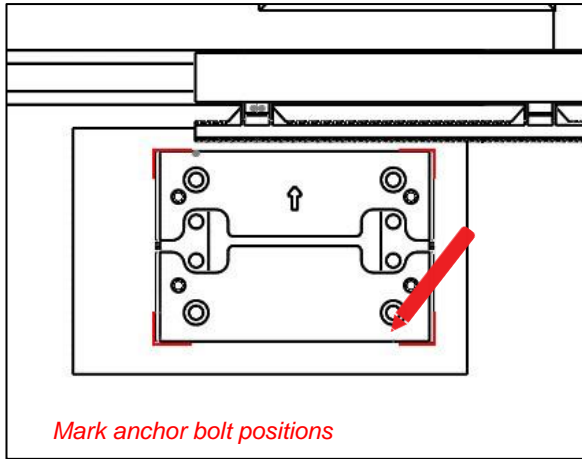

Fig 6

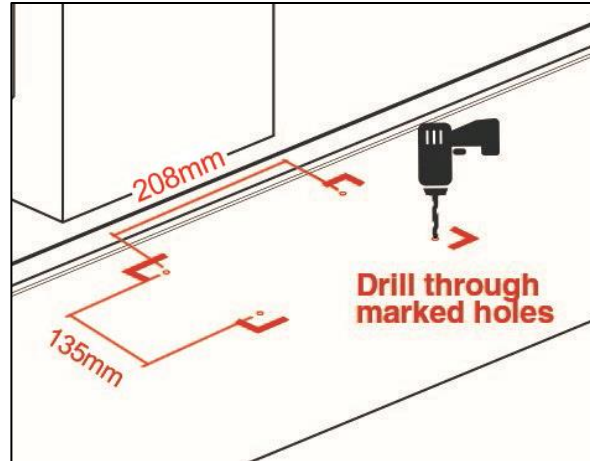

Fig 7

Step 6 - Fitting Mounting Plate & Motor:

- Fit motor mounting plate back into place and fit and tighten anchor bolts (as per figures 8 and 9).
- Fit motor back on mounting plate, ensuring the power cord is positioned into the end slot of the mounting plate in the direction of the power point, making sure there are no pinch points (as per Fig 10).
- Slide rubber grommet along the power cable and into the end slot of the mounting plate (as per figures 11 and 12).
- Bolt motor to the mounting plate using the M10 x 50mm bolts with spring and flat washers provided and tighten as required (as per figure 13).

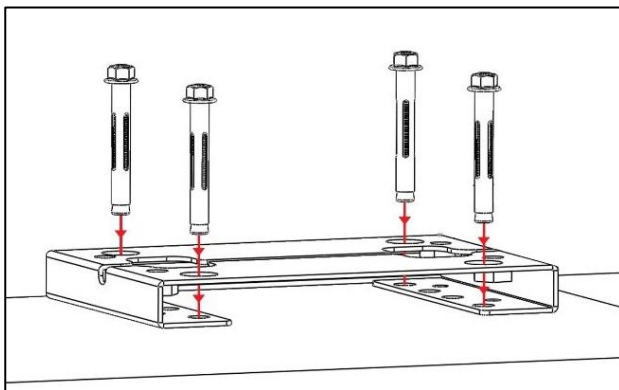

Fig 8

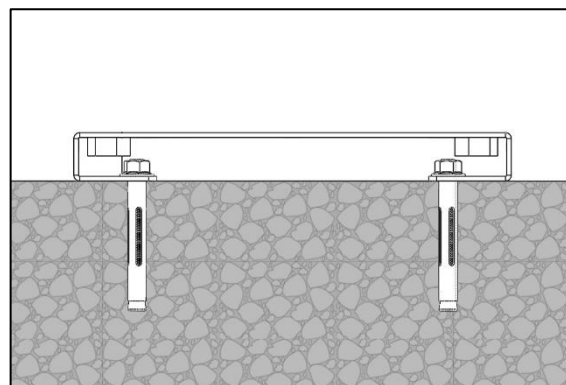

Fig 9



Fig 10



Fig 11



Fig 12

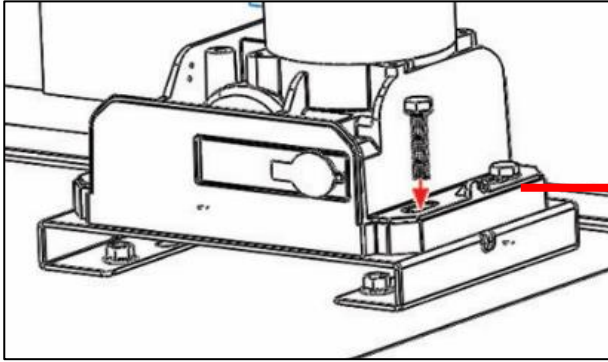

Fig 13

Insert the M10 x 50mm (Part 6d) bolts, spring washers, and flat washers through motor housing and screw into welded nut on the baseplate.

Hand-tighten set screws before final adjustment of motor.



Please ensure that the motor power cable is not plugged in at any stage before Step 9

Step 7 - Gear Rack & Motor Alignment:

- See Fig 16 for recommended gear rack mounting height.
- Insert the key and open the manual release bar to put the motor into manual mode and check that the motor cog rotates freely by hand (as per Fig 16).
- Ensure that the gate drive cog has a minimum clearance of 1-2mm along the entire length of gear rack fitted to the gate (as per Fig 14).
- Ensure motor cog and gear rack are correctly aligned. Under no circumstances should the gate motor drive cog carry any weight of the gate. It is the task of the gate castors or wheels to carry the weight of the gate (as per Fig 15).
- **If the gate doesn't slide freely by hand, adjust the height of the gear rack accordingly until the full length of gate slides freely by hand.**

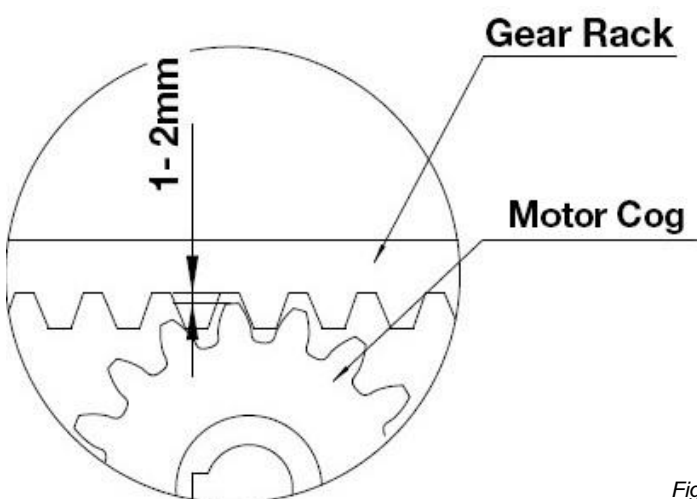
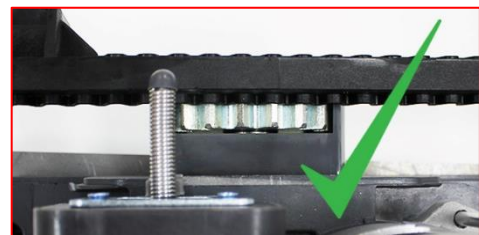

Fig 14



Gear rack correctly aligned at 90° to the motor cog

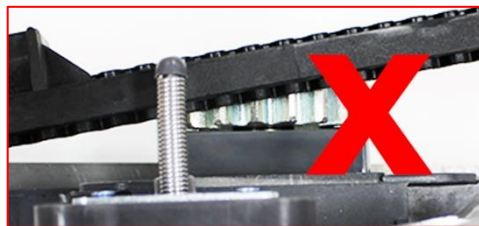

Fig 15

Gear rack misaligned. Do not attempt to use if misaligned.

At this stage of assembly, the cover is removed (not shown) and the power cable is still unplugged.



To put the gate motor into manual mode, insert the key and open the manual release bar as shown.

In manual mode, the gear can turn freely and the gate can be operated by hand.

Fig 16

At this stage of final assembly, the cover is removed (not shown) and the power cable is still unplugged.

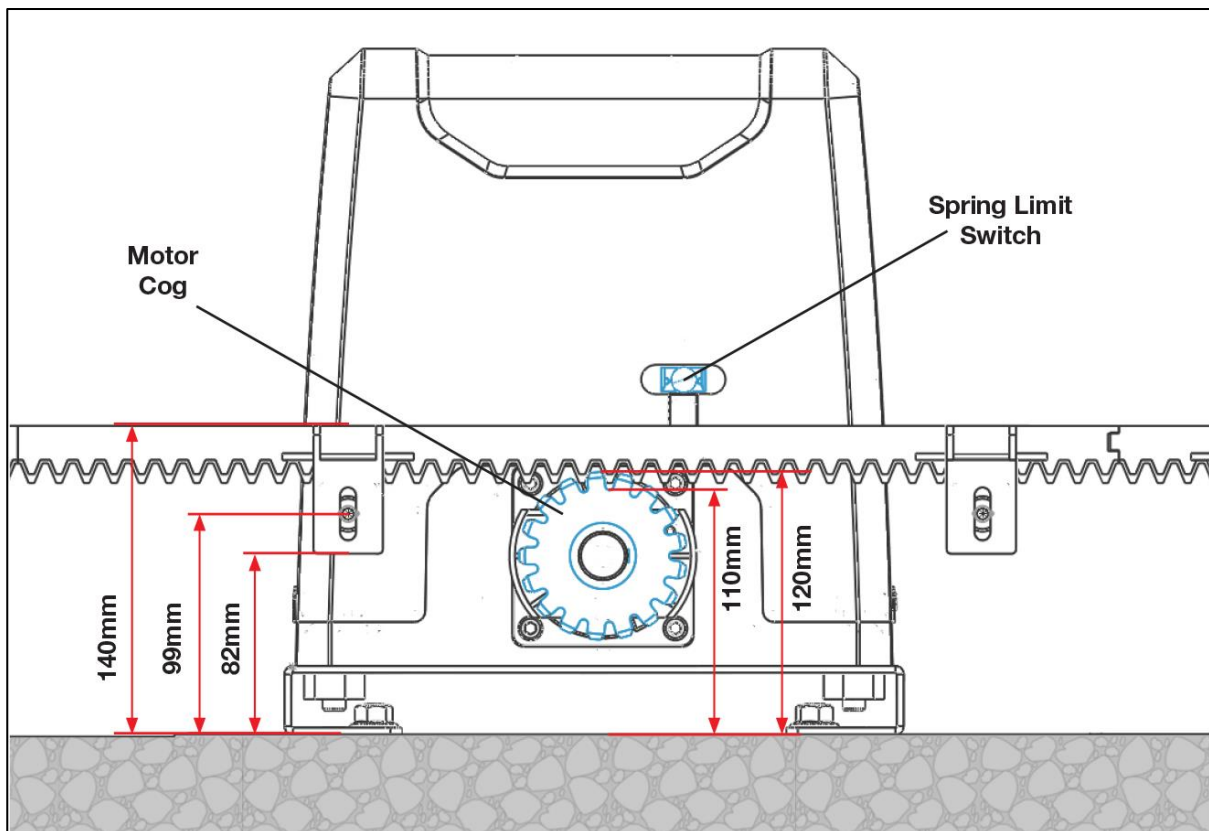

Fig 17

Now that your gear rack and motor are aligned, and your gate is sliding freely, fully tighten the motor mounting set screws (Part 6d) and reinstall motor cover and tighten screws provided.

Step 8 - Limit Travel Stops:

Included in your gate motor kit are two limit travel stops (Part 6a) which must be fitted to the gear racks on your gate to ensure safe operation.

The limit travel stops are designed to set the desired opening and closing position of your gate. These limit travel stops are designed to come into contact with the spring limit switch.

Please note: gates can open and close in different positions due to different weights of gates, terrains, slopes (uphill or downhill). The distance the gate will travel after contacting the spring limit switch may vary.

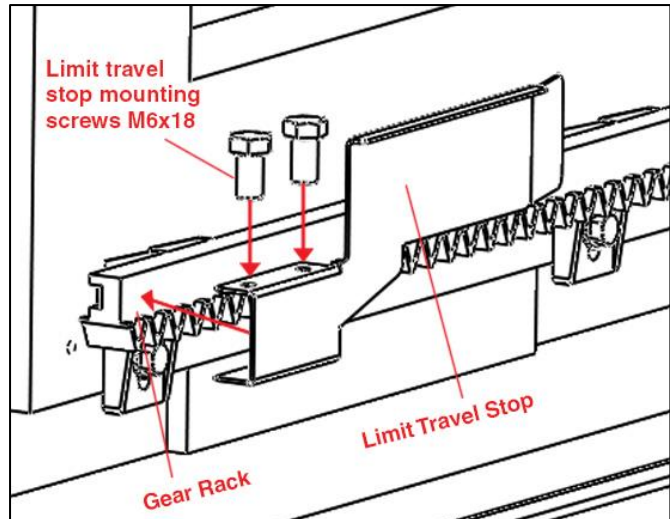

Fig 18

Instructions on setting the limit travel stops can be found on the next page

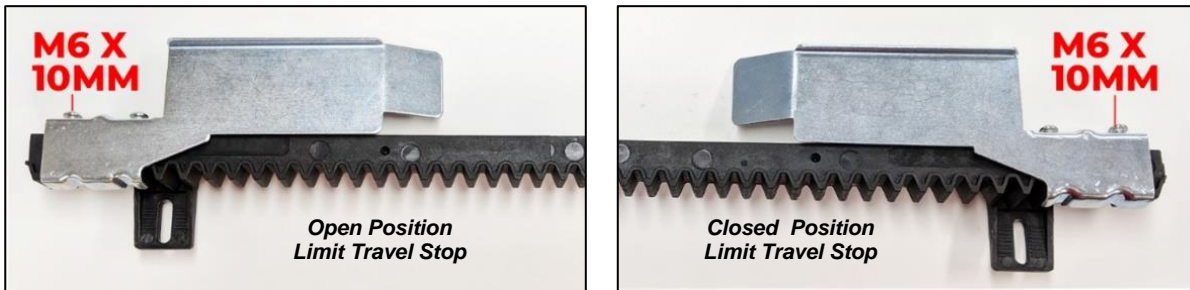

Fig 19

The installation of spring limit switch block is shown in Figure 19

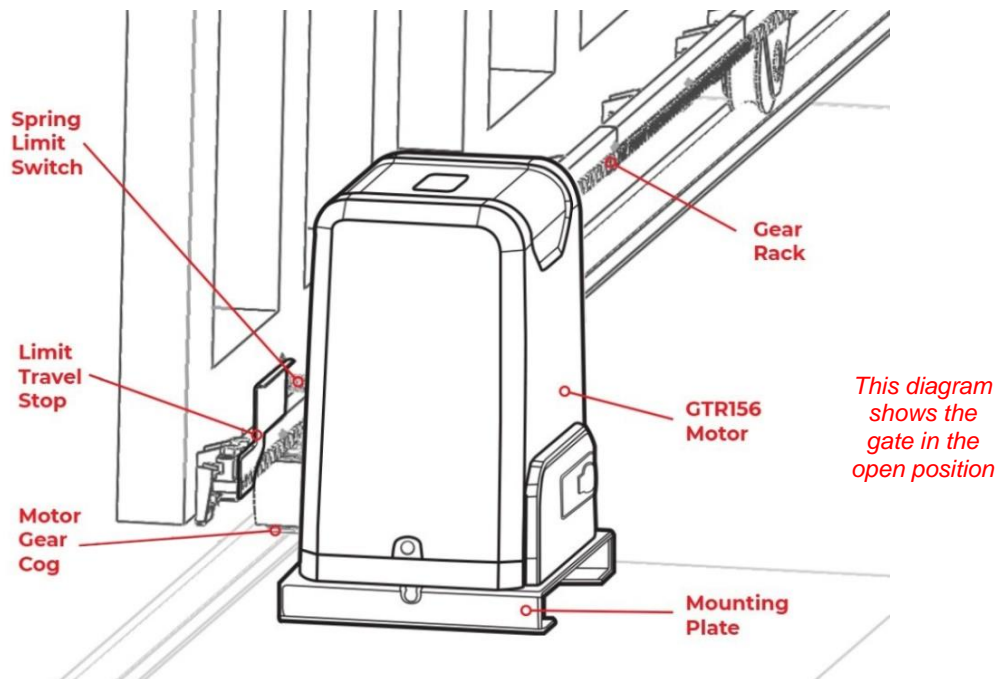

Fig 20

Setting the Limit Travel Stops:

Closed Position

- Position gate 150-200mm back from the gate end catch closed position. This will help in making sure you do not slam the gate into the end stop/catch when setting the closed position under power.
- Fit limit travel stop onto the top of gear rack at the point where it meets the spring limit switch on the motor.
- Tighten locking screws.

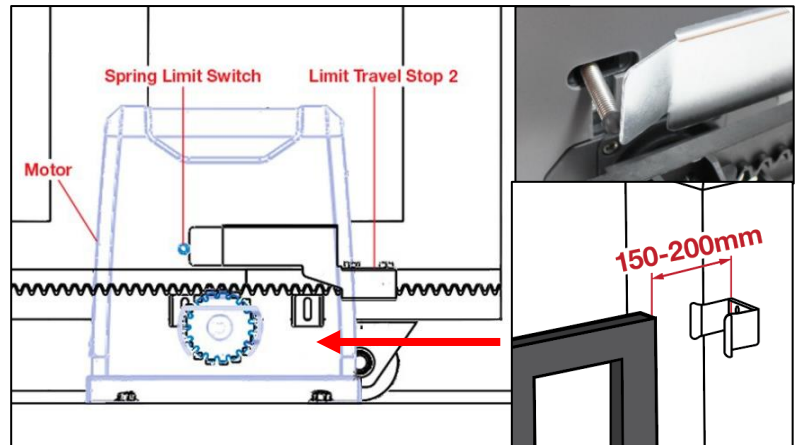

Fig 21

Open Position

- Position gate 150-200mm back from the gate stopper open position. This will help in making sure you do not slam the gate into the end stop/catch when setting the open position under power.
- Fit limit travel stop onto the top of gear rack at the point where it meets the spring limit switch on the motor.
- Tighten locking screws.

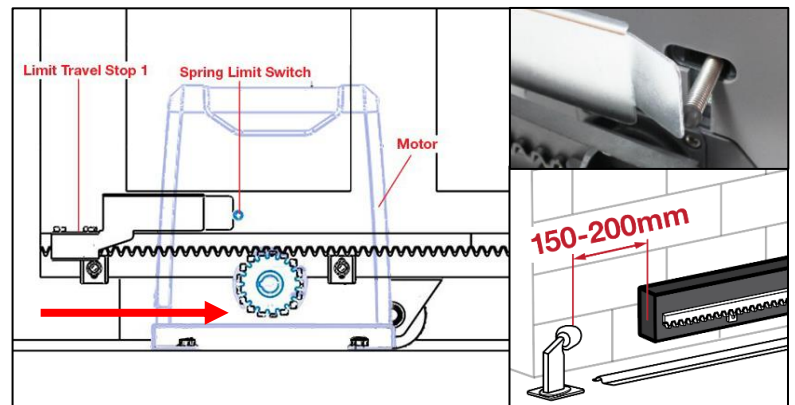

Fig 22

Test the spring limit travel stops by moving the gate manually until you hear a click, making sure contact is made with the spring limit switch on the motor.

To Reset: When setting new limit travel stop positions please ensure that you turn the power off and then on again. Turning the power off will reset the limit travel stop memory, allowing for new limit travel stop positions to be recognised by the motor.

Once satisfied the gate is opening and closing to the test limit switch position. Set the limit travel stop positions in place (see Step 9 and Step 10 for instructions on powering the motor and testing the limit switch positions).

Step 9 - Powering the Motor:

- Ensure that the outer cover has been fitted and fastened back onto the motor housing.
- Before powering up the motor make sure the gate can travel by hand in manual mode (key unlocked).
- Slide the gate to between the middle of the posts, approximately (see below diagrams).
- Lock the key (key locked) in readiness for automatic mode.
- Plug the power cord into an approved RCD protected weatherproof outlet.
- Remote controls (Part 4) included in this kit are factory paired ready for use.

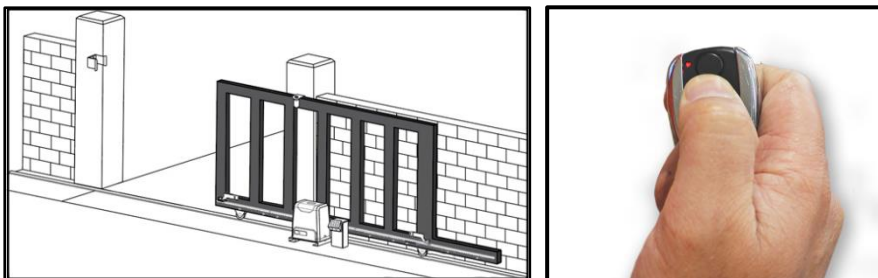

Note:

- The default setting is opening to the right. 
- Press the remote control and the gate will open until the spring limit travel stop hits the spring limit switch. Press the remote control again and the gate will close.
- Soft start/soft stop function - The GTR156 is set by default to provide the soft start/soft stop function. We recommend this default position is always maintained.

Your motor is now set up for basic remote-control operation. To set further functions and settings, see pages 19-29

Step 10 – Testing the Limit Travel Stops:

Testing the closed position

- Ensure motor is plugged in as per step 9 and the gate is in the open position.
- Press remote (remotes included in kit are factory paired to the motor). The gate will begin to close.
- The limit travel stops will hit the spring limit switch and the gate will stop.
- When the gate stops, measure the distance remaining between the gate and the desired closed position.
- You have now determined the closed position of the gate when the travel limit stop hits the spring limit switch.
- **Adjust the limit travel stops from the measurement you have taken to get your final gate closed position. The ideal closed final position for the gate frame is 10-15mm from closed gate end catch (GTR019).**

Warning:

Please allow space to ensure the gate does not impact against the gate catch or the end stop. See fig 23

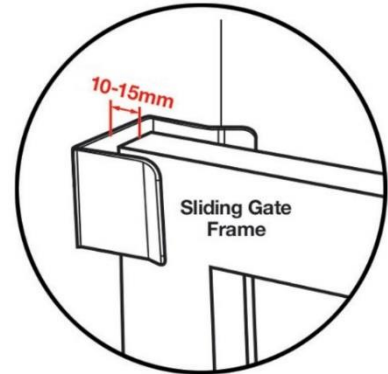

Testing the open position

- Press remote. The gate will begin to open.
- The limit travel stop will hit the spring limit switch and the gate will stop.
- When the gate stops, measure the distance remaining between the gate and the desired open position.
- You have now determined the open position of the gate when the travel limit stop hits the spring limit switch.
- **Adjust the limit travel stops from the measurement you have taken to get your final gate open position. The ideal open final position for the gate frame is 10-15mm from the gate stopper (GTR017).**

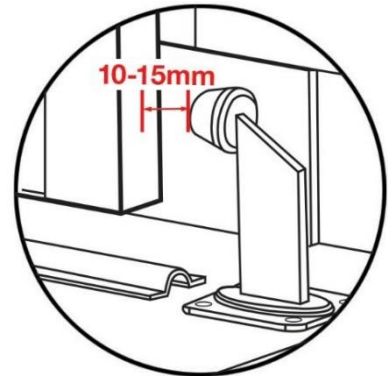

Fig 23

To Reset:

When setting new limit stop positions please ensure that you turn the power off and then on again. Turning the power off will reset the limit stop memory, allowing for new limit travel stop positions to be recognised by the motor.

Programming and Wiring:

Control board wiring diagram 01

Any works to the 240V AC must only be performed by a licensed electrician. Ensure power is off before any modifications are made.

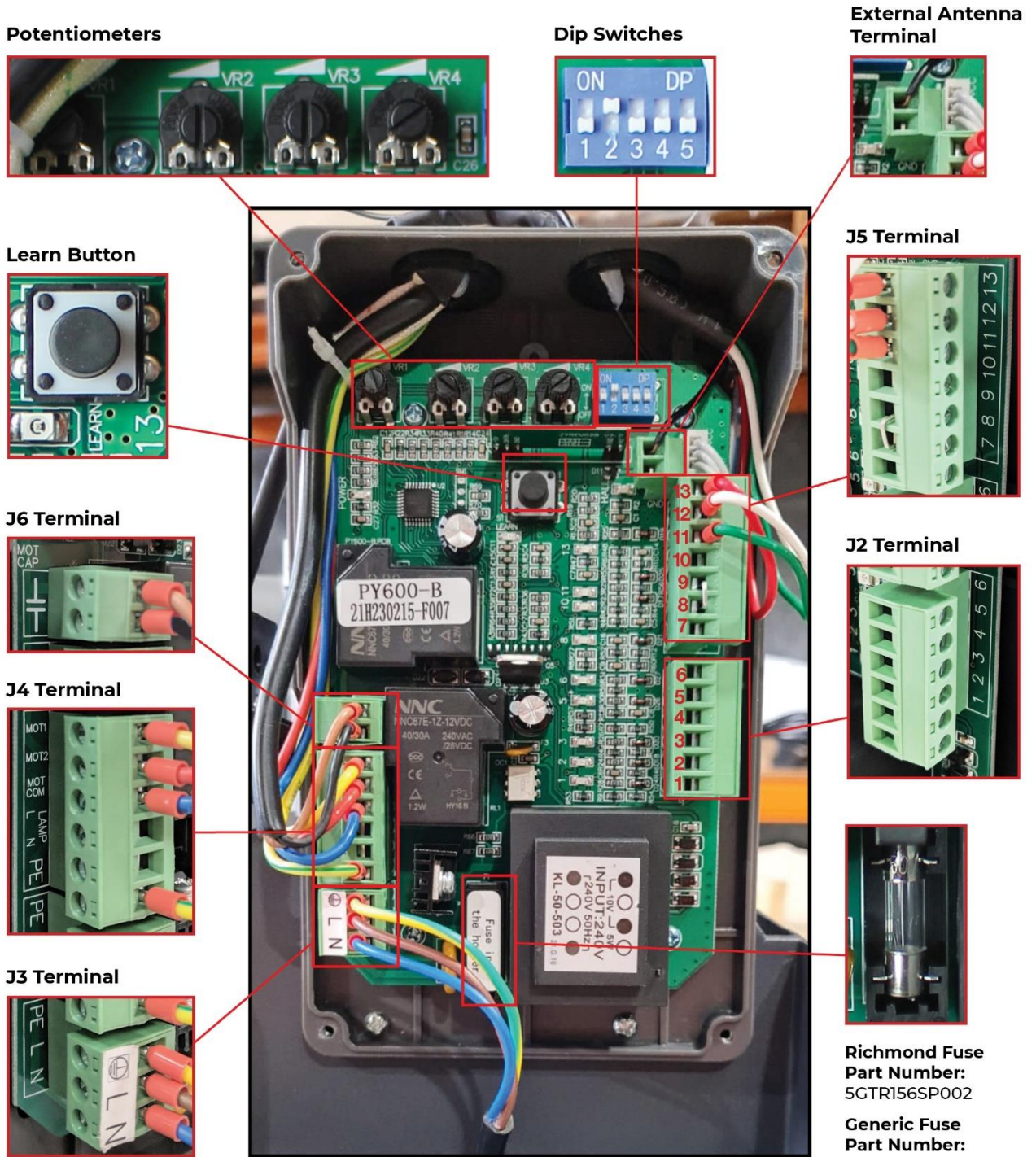

See next page for more details.

Fig 24

Programming and Wiring:
Control board wiring diagram 02

Hall Line

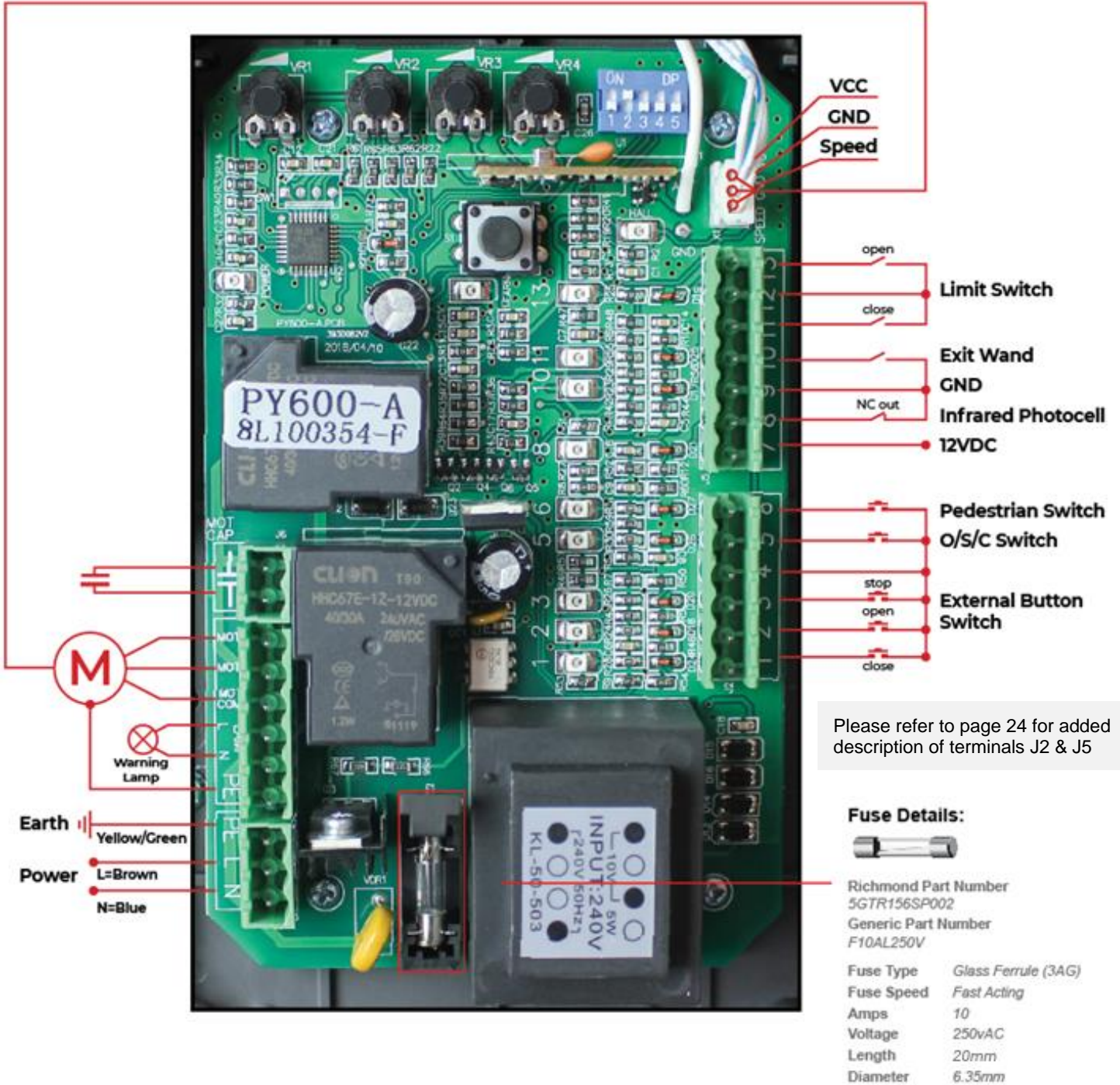







Fig 25

Dip Switch Adjustment:

All changes to these settings must be completed by a licensed electrician



Number	Description
	<p>Soft Start/Close Function OFF – enabled ON – disabled Default position is OFF (Do not disable)</p>
	<p>Limit Switch Setting OFF – Normal Open ON – Normal Close Default position is ON, this should not be changed.</p>
	<p>Remote Control Close Function 3 OFF 4 OFF: Factory default setting: The gate is operated by remote control operation only and will not close automatically. The gate will remain open until closed again with a remote.</p>
	<p>Optional Automatic Close Function Richmond strongly recommends that you install infrared photocells if using the motor in auto close mode.</p> <p>3 OFF 4 ON: automatic close delay time is 12s. 3 ON 4 OFF: automatic close delay time is 24s. 3 ON 4 ON: automatic close delay time is 36s.</p> <p>3 ON 4 OFF: Hard wire keypad. Automatic close function.</p>
	<p>Stall Force Mode (When in default position, detects obstacles, stops gate, and reverses. To adjust, refer to VR1: Stall Force Mode)</p> <p>Default position is OFF (enabled) this should not be changed. If the switch is set to ON, stall force mode will be disabled</p>

Further Settings & Programming:

All changes to these settings must be completed by a licensed electrician



VR1: Stall Force Mode

Maximum = More Force = Less sensitive

Minimum = Less Force = More sensitive

When the motor detects any obstacle or impact during opening the gate will stop and then return. During closing mode the gate will simply stop when detecting an obstacle or impact.

Rotate VR1 clockwise to increase the stall force, anti-clockwise to decrease. Factory default setting is midway, for any dial adjustment required above this. Check your gate is free rolling with no resistance capable of being moved freely by 1 person.

For safety we strongly recommend that Stall Force Mode is left enabled (Dip switch 5 is at the OFF position). Do not turn Dip switch 5 to the ON position.

VR2: Brake Force Adjustment

For adjusting brake force at the limit position during gate opening and closing. This should only be adjusted for heavy gates that need additional force to brake when limit switch is detected.

Rotate VR2 clockwise to increase, counter-clockwise to decrease. Default setting is at minimum.

VR3: Soft Closing Travel Time

This controls how many seconds your gate runs during the soft close function. Rotate VR3 clockwise to increase the soft closing travel time. This motor has a default soft closing time which cannot be decreased.

VR4: Motor Output Force Adjustment

For best performance set the torque at the lowest setting that you require.

Rotate clockwise to increase, counter-clockwise to decrease.

Default setting is at maximum.

All changes to these settings must be completed by a licensed electrician



J2 Terminal: (as per fig 17)

- Terminal 1:** Optional External Close Push Button Switch.
- Terminal 2:** Optional External Open Push Button Switch.
- Terminal 3:** Optional External Stop Push Button Switch.
- Terminal 4:** Common Terminal for All Optional Push Buttons.
(Hard-Wired keypad connection between terminals 4 & 5)
- Terminal 5:** Optional External Open/Stop/Close Single Push Button
(does the 3 open/stop/close functions)
- Terminal 6:** Optional External Push Button Pedestrian Switch

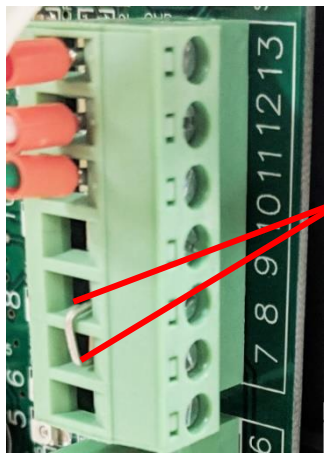

J5 Terminal: Limit Switch and Accessories

Additional accessories sold separately

- Terminal 7:** Power supply for accessories of J5 (+15V)
- Terminal 8:** Photocell input (Normally Closed). If no photocell is fitted use jumper between terminals 8 & 9.
- Terminal 9:** Ground/Earth (GND)
- Terminal 10:** Exit wand connection between terminals 9 & 10
- Terminals 11, 12, and 13 are factory fitted (pre-wired)**
- Terminal 11:** Close spring limit switch
- Terminal 12:** Spring limit switch common terminal
- Terminal 13:** Open spring limit switch

Please Note: If changing gate direction terminals 11 & 13 on Terminal J5 will need to be swapped.

Connecting Wires to the Terminal:

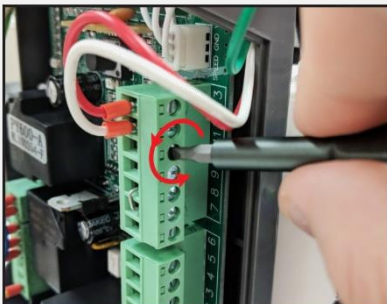

Using a screwdriver, loosen the screw on the side of the terminal.

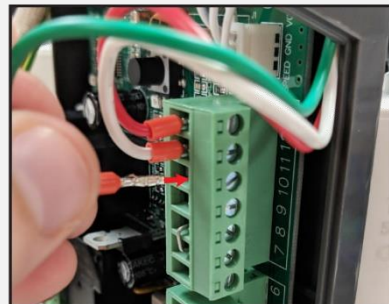

Insert the wire into the number on the terminal that you are looking to connect to. Refer to Pages 20 & 21

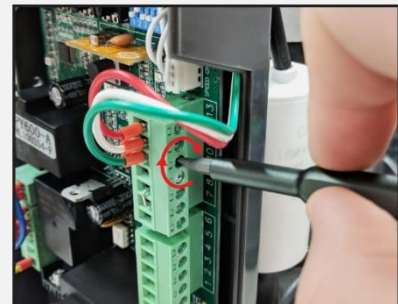

Tighten with a screwdriver to secure the wire in place.

All changes to these settings must be completed by a licensed electrician.

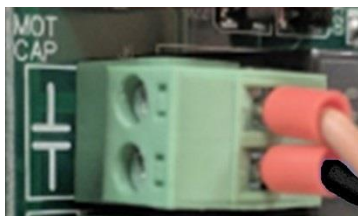

J6 Terminal:

Motor Capacitor



J4 Terminal:

MOT1: Motor Terminal, swap with MOT2 to change gate direction.

MOT2: Motor Terminal, swap with MOT1 to change gate direction.

MOTCOM: Motor Common Terminal.

LAMP (L&N): Connection for warning lamp.

PE: Motor and warning lamp earth

Please Note: If changing gate direction terminals 11 & 13 on Terminal J5 will also need to be swapped with each other.



J3 Terminal - Main Power Terminal:

PE: Earth (yellow/green wire).

L: Power (brown wire).

N: Power (blue wire).



ANT Terminal:

Used for fitting an aftermarket external antenna, with or without shielding

Maintenance schedule.

Performing preventative maintenance will extend the life of your gate motor.

Regular maintenance will also minimise potential faults/failures and equipment repairs/replacements.

ONGOING	
Gate Track	- Keep the track clear of any debris.
Motor	- Keep the area around/under the motor dry and clear of debris, dirt, or grass. - Do not allow water to pool around the motor.
QUARTERLY	
Motor	- Operate the manual release. Lubricate the release, plunger, and lock with a synthetic spray lubricant. - Check the rubber grommet is correctly in place in the motor housing.
Gate Guide	- Check the guide rollers/rail are not binding. - Lubricate with synthetic spray lubricant.
Track Wheels	- Lubricate the wheel axles with synthetic spray lubricant.
Drive Gear	- Lubricate the shaft behind the drive gear, between the gear and housing. - The drive gear teeth do not need lubricating.
ANNUALLY	
Motor	- Turn off the power. Remove the outer cover and inspect the motor for any signs of moisture, bugs, dirt etc. - Visually inspect through the clear case for any signs of corrosion. - Check motor mounting bolts are tight. - With the cover back on, apply a bug barrier spray around the base of the motor.
Gear Rack	- Operate the gate manually and inspect the gear rack for correct spacing. - Visually inspect the gear rack for any damaged/missing teeth. - Check for any damaged missing mounting tags or screws. - Inspect the Open/Close travel limit stops for damage and check for correct spring contact.
Track Wheels	- Lift the gate slightly and check the wheels spin freely and are free of damage.
Gate Track	- Check for any loose/missing mounting screws/bolts.
SPECIAL MAINTENANCE	
Locations with extreme weather	- In coastal areas, additional component protection may be necessary. Consult Richmond Wheel and Castor if excessive corrosion occurs.

Troubleshooting:

Any works done to the motor must be completed by a licensed electrician and only whilst the power is off and the motor is unplugged.

Problem	Possible Reason	Solution
The gate cannot open or close normally, and LED does not light.	<ol style="list-style-type: none"> 1. The power is off. 2. Fuse is blown. 3. Control PCB is damaged 	<ol style="list-style-type: none"> 1. Switch on the power supply. 2. Licensed Electrician: Check the fuse (see page 20-21) and replace if necessary. 3. Contact Richmond Wheel & Castor Co for replacement PCB (board)
Remote control does not work.	<ol style="list-style-type: none"> 1. Remote control battery is flat. 2. Remote control is not paired correctly. 	<ol style="list-style-type: none"> 1. Check LED lights up when button is pressed. If not, change the remote-control battery (A27 battery required) 2. Licensed Electrician: Repeat pairing procedure (refer to page 29)
The gate opens but cannot close.	<ol style="list-style-type: none"> 1. Stall force is set too low. 2. Photocell settings incorrect. 3. Photocell beam is interrupted (if installed). 	<ol style="list-style-type: none"> 1. Increase stall force to the minimum value that the gate still operates. (see page 23) 2. Licensed Electrician: If photocell is not connected, ensure that there is a jumper wire between 8 and 9 on the J5 terminal. If photocell is connected, ensure the wiring is correct. 3. Check and remove any obstructions.
Gate does not move when button is pressed, but motor makes a noise.	<ol style="list-style-type: none"> 1. Gate is out of alignment. 2. Capacitor has blown or is otherwise damaged. 	<ol style="list-style-type: none"> 1. Put motor into manual mode and check if it can be opened freely by hand. If not, check that the gear rack freely moves over the motor cog. 2. Contact Richmond Wheel & Castor Co for replacement PCB (board)
Gate does not stop at the limit switch when opening/closing.	<ol style="list-style-type: none"> 1. The brackets are positioned incorrectly. 2. The gate opening direction is incorrect. 3. Limit switch is damaged. 	<ol style="list-style-type: none"> 1. Check that LEDs 11/13 turn off when spring is contacted and reposition if required. 2. Licensed Electrician: Swap MOT1 and MOT2 lines on terminal J4 (refer to page 20) and swap over lines 11 & 13 on terminal J5 ref to fig 26 page 21. 3. Check wiring for any damage. Contact Richmond Wheel & Castor for a new limit switch if required.
Gate does not fully open or close	<ol style="list-style-type: none"> 1. The gate meets an obstacle. 2. Motor output force is too low. 3. Stall force is too low. 	<ol style="list-style-type: none"> 1. Remove the obstacle. 2. Licensed Electrician: Increase VR4: Motor Output Force Adjustment (Page 23). 3. Licensed Electrician: Increase VR1: Stall Force (Page 23).

For support or assistance with troubleshooting, visit gatesupport.richmondau.com

Or ring your local Richmond Wheel & Castor Co Branch

AU: 03 9070 5713 **NZ:** 0800 61 71 81 **International:** +613 9551 2233

The below steps must be completed by a qualified electrician

Clearing Remote Controls:

To delete all paired remote controls, press and hold the button 'S1' for approx. 8 seconds. When the 'LEARN' LED turns off, all previously paired remote controls will be deleted.

Pairing Additional Remote Controls:

Remove motor outer cover and continue to remove the clear PCB cover, press the button 'S1' on the control board, until the 'LEARN' LED turns on, then release the button. While the light is on, press the first button on the remote control twice, the 'LEARN' LED will flash repeatedly and then turn off when remote control is paired.

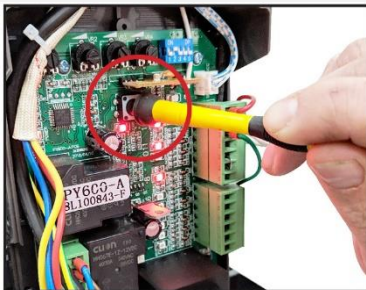

Press and hold the learn button (S1) until the Learn LED flashes ON.

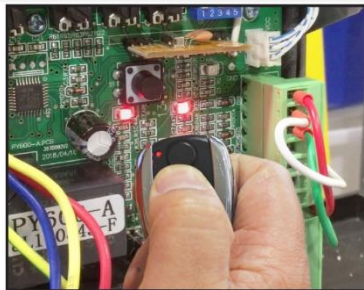

While the light is on, press the first button on the remote control twice.

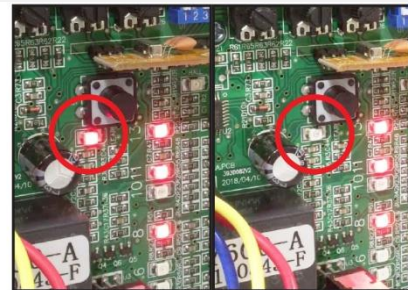

The Learn LED will flash repeatedly and then turn OFF. when the remote is paired.

Technical Support

For support or assistance with installing your gate motor, contact our gate support team:

Visit gatesupport.richmondau.com

AU: 03 9070 5713 **NZ:** 0800 61 71 81 **International:** +613 9551 2233

Richmond Wheel & Castor Co declines all responsibility for any consequences resulting from improper use of the product, or use which is different from that expected and specified in the present documentation.

Richmond Wheel & Castor Co declines all responsibility for any consequences resulting from failure to observe Good Technical Practice when constructing closing structures (door, gates etc.), as well as from any deformation which might occur during use.

Additional Drawings and Measurements:

