

Push Clip Lid Latch Installation Guide

Step 1: Choose the position of the latch on the front 1/4 of the lid as shown on the diagram.

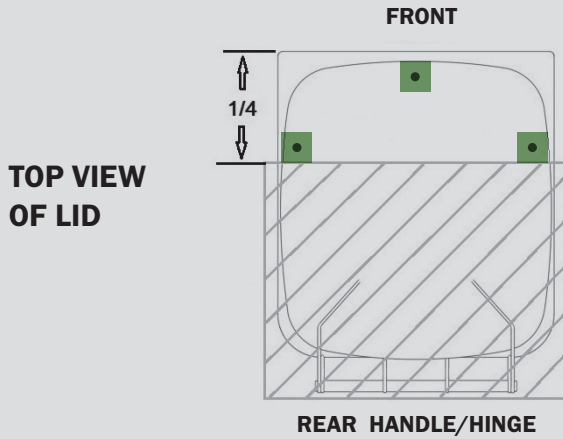

Latch positioning considerations:

The latch can be attached to either side, or the front of the lid. The best position depends on a range of parameters including the waste stream and collection system used. For advice on positioning please contact us and we'll be happy to help you identify the ideal placement for your lid latches.

- SafeWaste recommends checking with your local hauler or municipality if positioning the lid latch in the front center of the lid to make sure the latch won't interfere with their lifter mechanism.

Usual Recommended Positions

Step 2: Check the scale of the marking template below to ensure an overall length of six inches, adjust the printer page size settings if required. Cut out and fold the template then make a hole on the centre mark.

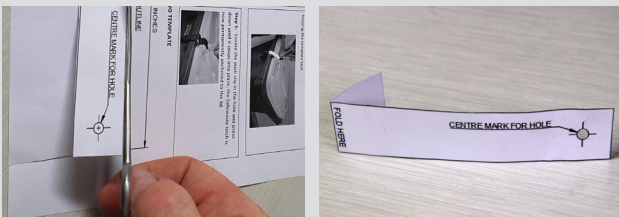

Step 3: Align the folded edge with the bottom lip of the cart making sure it is clear of any ribs or obstructions, then lay the template over the lid and mark the centre point keeping the template taut.



Step 4: Drill a 1/2 inch (12.7mm) hole through the lid on the centre point mark. A regular drill bit works, but a 1/2 inch (12.7mm) centre drill is best.



Step 5: Locate the push clip in the hole and press down until it snaps into place, the SafeWaste Latch is now permanently anchored to the lid.



HOLE MARKING TEMPLATE

