

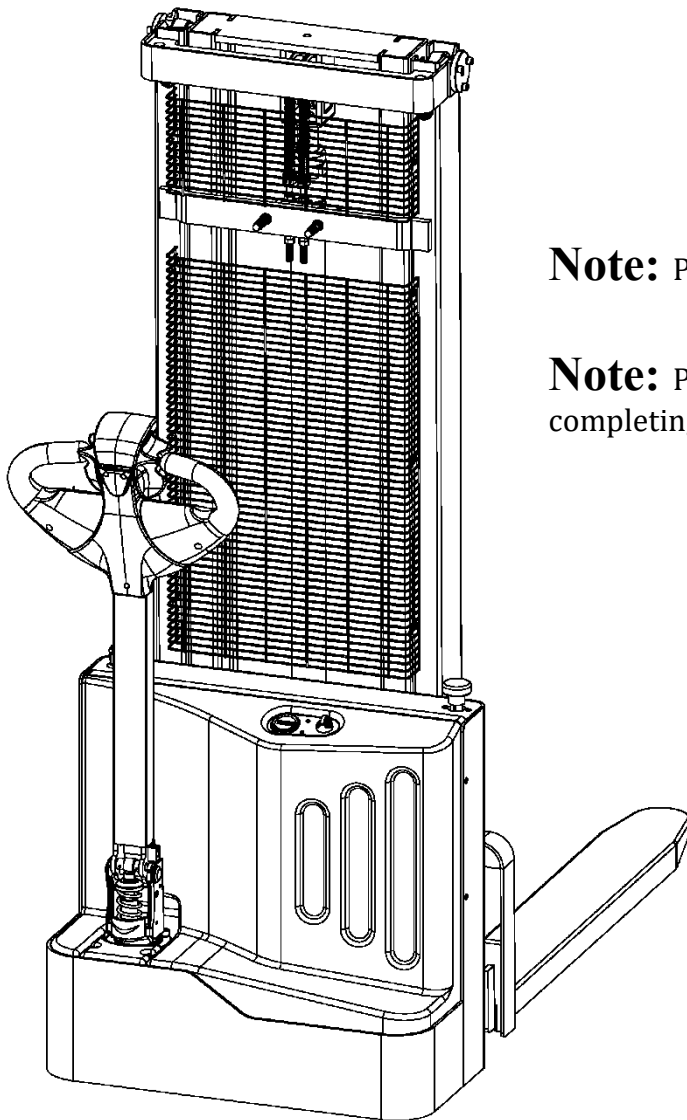

# Specification Manual

## FSR106 Full Electric Stacker



**Note:** Please read this manual before using!

**Note:** Please do not use it before completing the installation!

# Contents

<b>Chapter 1</b>	<b>Foreword</b>	<b>1</b>
<b>Chapter 2</b>	<b>Specifications</b>	<b>2</b>
<b>Chapter 3</b>	<b>Description of the machine</b>	<b>4</b>
<b>Chapter 4</b>	<b>Safety regulations</b>	<b>5</b>
<b>Chapter 5</b>	<b>Use of the machine</b>	<b>7</b>
<b>Chapter 6</b>	<b>Battery</b>	<b>8</b>
<b>Chapter 7</b>	<b>Maintenance</b>	<b>9</b>
<b>Chapter 8</b>	<b>Hydraulic diagram</b>	<b>11</b>
<b>Chapter 9</b>	<b>Electrical diagram</b>	<b>12</b>
<b>Chapter 10</b>	<b>Trouble shooting</b>	<b>13</b>

# **Chapter 1**

## **Foreword**

This manual contains all the instructions for the use of the machine and the necessary knowledge for its correct use.

Read this manual carefully before the machine is taken into use to avoid errors. Correct operations and regular inspections are factors of vital importance for the operating economy and lifetime of the machine.

These important aspects are described in the following related sections. This machine has been designed to lift and transport loads on perfectly even floors. A nameplate can be found on the machine indicating the lifting capacity that must never be exceeded both for the safety of the personnel and not to damage the vehicle. Please observe the safety, use and maintenance regulations to the letter. Any mounting of extra equipment on the machine must be authorized by the manufacturers.

This manual gives useful indications for the correct use and maintenance of the forklift truck to which it refers, it is, therefore, essential to pay great attention to all the paragraphs that illustrate the simplest and safest way of using the stacker.

All the information contained in this booklet is based on the data available at the time of printing, the manufacturer reserves the right to modify its products at any time, without notice and without liability. It is therefore advisable to regularly check for any changes.

The manufacturers shall not be held liable in case of faults or accidents due to negligence, incapacity, installation by unqualified technicians and improper use of the electric stacker.

## Chapter 2 - Specifications

Technical specifications and major dimensions are shown in TABLE 1 and FIGURE 1, Respectively.

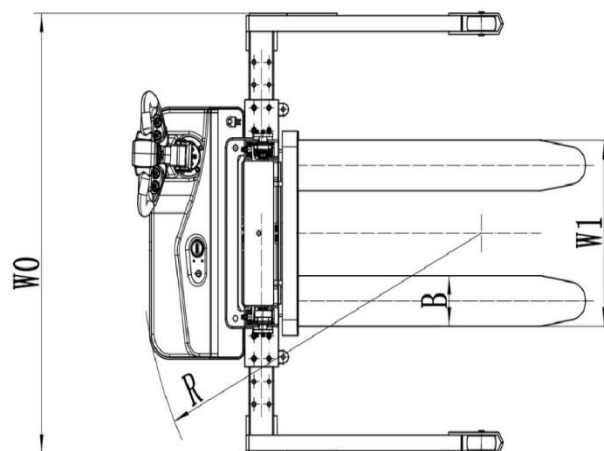
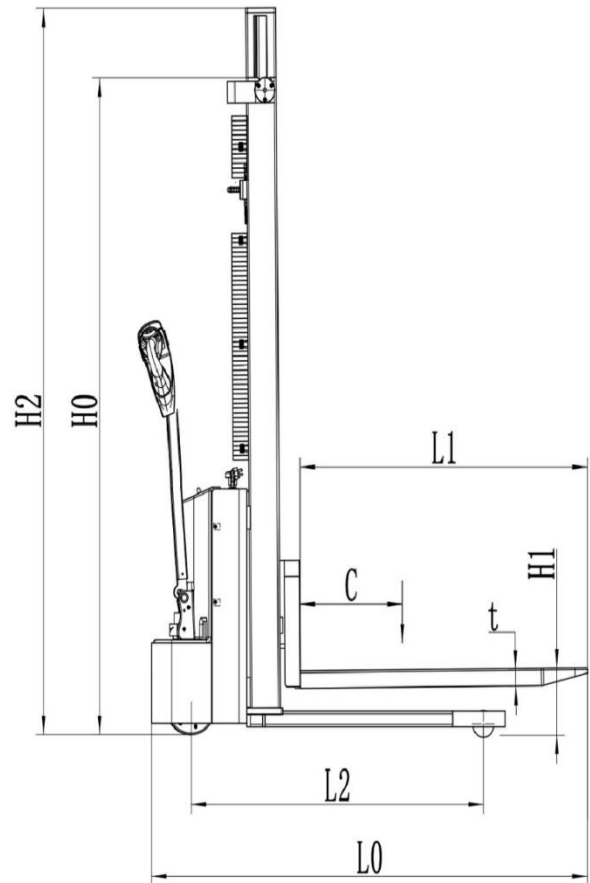

FIGURE 1

**TABLE 1**

Model	Unit	FSR106
Load Capacity	Q (kg)	1300
Load center	C (mm)	400
Max. height of forks H1	H1(mm)	3000
Max. height of machine H2	H2 (mm)	3540
Fork length L1	L1(mm)	1150
Overall fork width W1	W1(mm)	850
Fork size	b*t (mm)	160*55
Min. turning radius	R (mm)	1385
Aisle width with pallet 1000*1200 across forks	mm	2280-2880
Moving speed	km/h	4/4.5 (loaded/unloaded)
Min. height of forks	mm	90
Lifting speed	mm/s	75/116 (loaded/unloaded)
Lowering speed	mm/s	70/56 (loaded/unloaded)
Max. travel grade	%	4/10 (loaded/unloaded)
Wheel base	mm	1170
Battery	V/Ah	24/70
Driving motor	kw	0.75
Lifting motor	kw	2.2
Overall length L0	L0 (mm)	1775
Overall width W0	W0 (mm)	1400
Overall height H0	H0 (mm)	2085
Self weight (with battery)	kg	591

### Chapter 3 - Description of the machine

This machine is an electric forklift truck with tiller bar drive and is perfect for storing and transporting loads on perfectly even surfaces. The controls are easy to see and use. The drawing shows its main specifications.

FIGURE 2

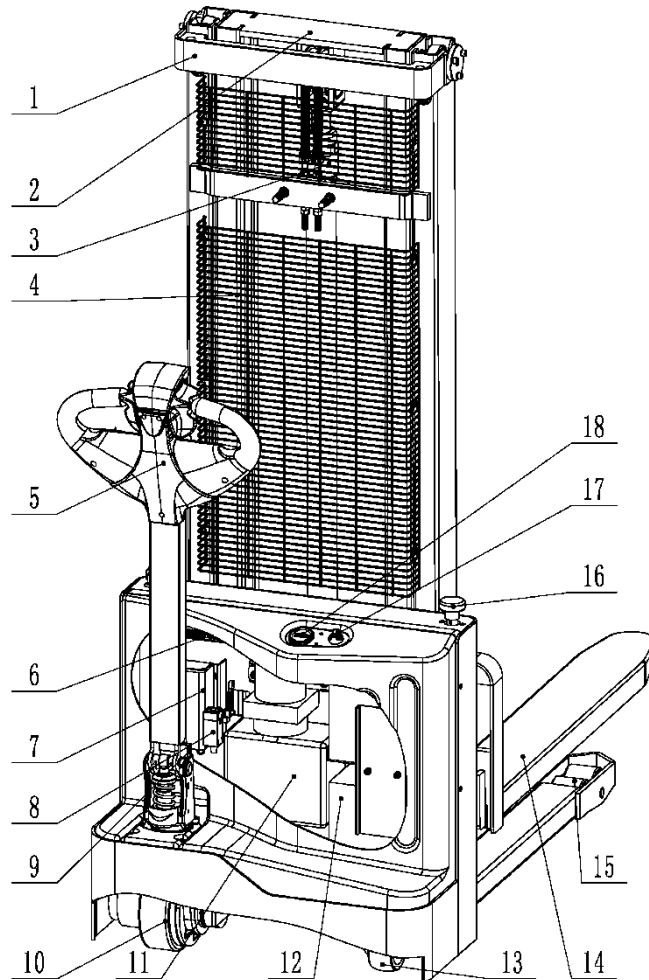

- |                                  |                           |
|----------------------------------|---------------------------|
| 1) Frame                         | 10) Driving Wheel         |
| 2) Inner Frame                   | 11) Power Pack            |
| 3) Cylinder                      | 12) Battery               |
| 4) Protective net                | 13) Caster                |
| 5) Handle                        | 14) Fork                  |
| 6) Controller                    | 15) Loading Wheel         |
| 7) Charger                       | 16) Emergency Stop Switch |
| 8) Height Limit Switch           | 17) Key                   |
| 9) Handle Angle interlock switch | 18) Battery Indicator     |

## Chapter 4 Safety Regulations

### Safety Device

- A) Emergency Stop Switch (No.16/ Figure 2)
- B) Brake (No.10/ Figure 2)
- C) Handle Angle interlock switch (No.9/ Figure 2)
- D) Height Limit Switch (No.8/ Figure 2)
- E) Flow-limiting Valve (No.11/ Figure 2)
- F) Pressure-limiting Valve (No.11/ Figure 2)
- G) Emergency (No.5/ Figure 2)
- H) Protective Net (No.4/ Figure 2)

### Safety Regulations

The driver must carry out the following instructions of use in the driving position in way to remain reasonably distant from the dangerous zones (such as masts, forks, chains, pulleys, driving and stabilizing wheels and any other movable part), that can cause the crushing of hands and/or feet. The truck must be used according to the following regulations:

- 1) The driver of the machine must be aware of the instructions for use of the vehicle and wear appropriate clothing and a helmet.
- 2) Only professionally trained persons over 18 years old may drive.
- 3) The driver responsible for the forklift truck must not allow unauthorized personnel to drive the truck or to step onto the forks or the platform. While the truck is in movement the operator must reduce speed in curves, in narrow corridors, through doors or on irregular surfaces. He must keep unauthorized personnel away from the area where the truck is working and immediately warn people if they are in danger; if, in spite of this warning there is still someone in the work area the driver must immediately stop the truck.
- 4) It is forbidden to stop in areas where there are moving parts and step on the fixed parts of the truck.
- 5) The driver must avoid sudden stops and fast inversions of movement.
- 6) In case of slopes with maximum permitted inclination, the driver must keep the load above the truck and reduce speed.
- 7) When driving the driver must make sure that visibility is good and that there are no obstructions when reversing.
- 8) If the truck is transported in lifts he must enter them with the loading forks in front (first make sure the lift has a sufficient load).
- 9) It is absolutely forbidden to disconnect or dismount the safety devices. If the truck is used in areas with a high risk of fire or explosion, it must be approved for this kind of use.
- 10) The loading capacity of the truck must in no case be exceeded. The

driver must ensure that the load is evenly placed on the forks and in perfect order. Uneven loading not only damages stacker but also causes upsetting.

- 11) It is forbidden to move the truck with the forks in their upper position. The forks must not be lifted more than maximum 300mm when driving. This is allowed only when manoeuvring to put down and pick up loads.
- 12) Before beginning work the driver of the truck must check:
  - a. The performance of the service and parking brake
  - b. The loading forks are in perfect order
  - c. The wheels and the rollers are not damaged
  - d. The battery is charged, well fixed and the elements perfectly dry and clean
  - e. All the safety devices are in working order
- 13) Once the battery signals (ref.7/FIGURE 4) that it only has 20% charge left, the truck must stop being used and, therefore, recharged.
- 14) The truck must always be used or parked shelter from rain and snow and in no case must it be used in very damp areas.



## Chapter 6 Use of the machine

### Set up

Before starting the machine check that all the parts are in perfect condition, check the performance of all the units and the safety devices.

Move the truck with battery current and never with rectified alternating current so as not to damage the electrical components.

### Tiller Bar

The truck can be driven by a person either from the ground or standing on the platform.

The steering angle is  $150^{\circ}$ .

The tiller bar operates directly on the driving wheel, therefore, to change direction turn it in the required direction.

To move the truck (see figure 3) keep the tiller bar in its central position (position B), while to stop it to move it to its upper position (position A) or in its lower position (position C).

When released the tiller bar returns automatically to its upper position (position A) and acts as a parking brake.

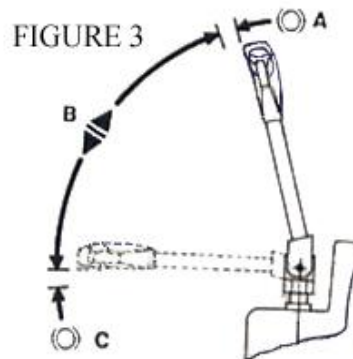

### Controller Handle (Figure 4)

- 1) Travel Switches
- 2) Belly switches  
(a kind of safety switch during operation)
- 3) Horn button
- 4) Descending button
- 5) Ascending button
- 6) Electricity meter

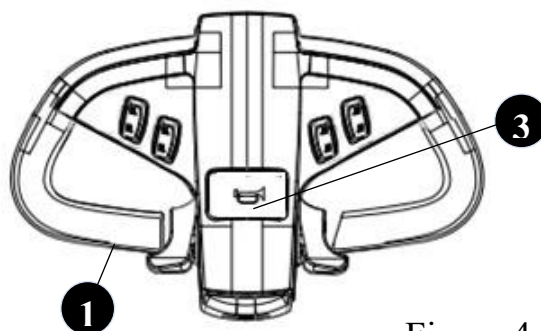

Figure 4

## Movement

Before moving the truck check that the horn and the brake work and that the battery is completely charged. Turn the key to the ON position and move the tiller bar to its movement position. Turn the governor slowly and move towards the relative work area. To brake or stop turn the governor in the opposite direction. Always steers the truck slowly as sudden movements can provoke dangerous situations (particularly when the truck moves at high speeds). Always drive with the load in a low position, reduce speed in narrow corridors and on curves.

## Stacking

- 1) Approach the shelving carefully with the load low (the platform must be high and the truck driven by a driver on the ground)
- 2) Make sure that the legs of the truck are free to move under the pallet or in the shelving. The best way to do this is to put the side of the pallet to be lifted in a perfect line with the top pallet in the shelving using it as reference. In this way loading and unloading will be easier.
- 3) Lift the load until it rises above the level of the shelf.
- 4) Move slowly forwards and stop when the load is above the shelf, at this point lower the forks so as to free them from the pallet and not exert force on the underlying shelf. Make sure that the load is safely positioned.
- 5) Move slowly backwards making sure the pallet remains firmly positioned.
- 6) Lower the forks to their position of movement (figure 5-figure 6).

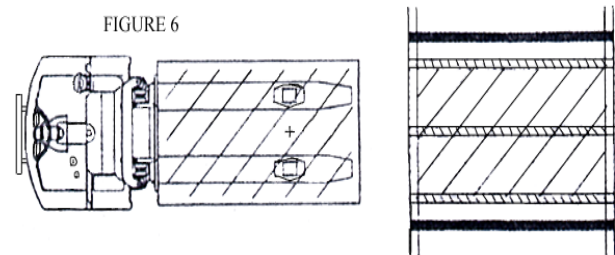

7)

## Unloading

- 1) With the forks lowered and perpendicular approach the shelving and enter under the bottom pallet.
- 2) Return with the forks out of the pallet.
- 3) Raise the forks to required height and slowly move towards the pallet to be unloaded. At the same time make sure that the forks enter under the pallet easily and that the load is safely positioned on the forks.
- 4) Raise the forks until the pallet is lifted from the level of the shelf.
- 5) Move slowly backwards in the corridor.
- 6) Lower the load slowly at the same time making sure that the forks do not touch obstacles while lowering.

**WARNING: Always check the weight of the load with the lifting**

capacity relative to the height indicated on the appropriate plate.

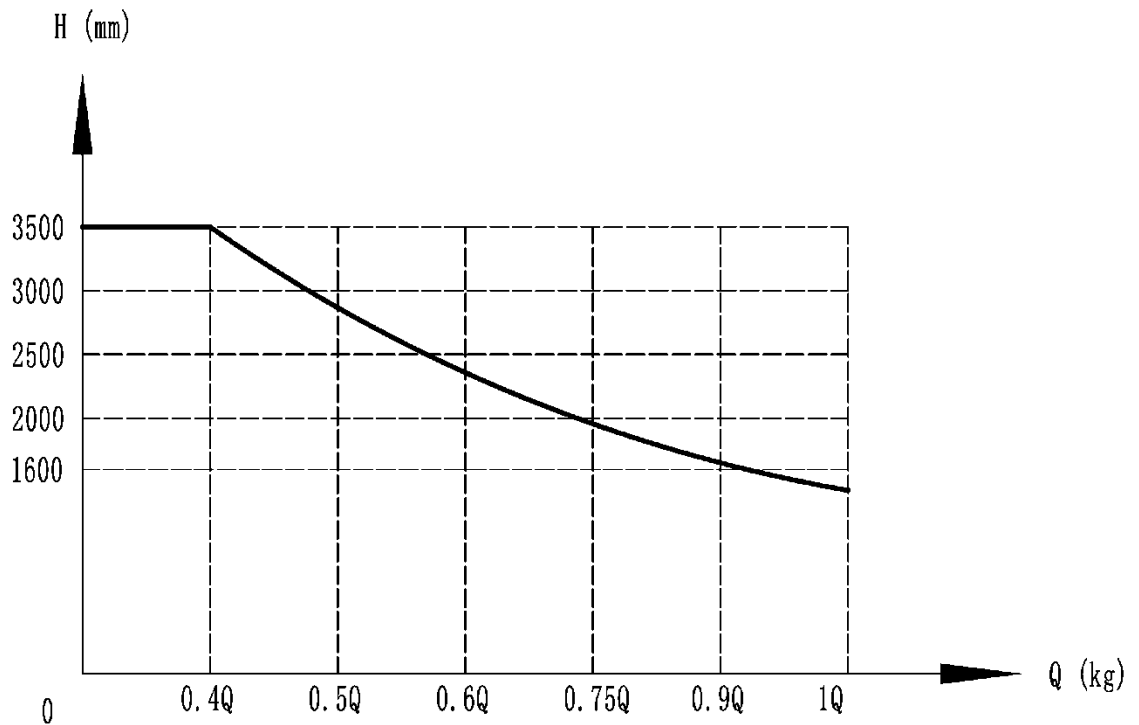

**WARNING:** When the load is lifted steering and braking man-oeuvres must be carried out slowly and very carefully.

**Transport**

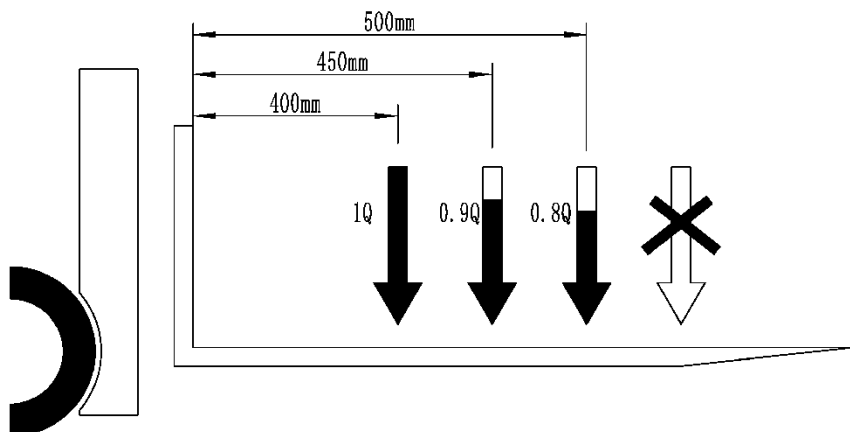

## Chapter 6 Battery

Inspection, charging and substitution of the battery must be carried out by authorized personnel follow the manufacturer's instructions.

It is forbidden to smoke or keep inflammable or spark-producing material near the truck or the battery charger. The area must be kept well aired.

The caps of the elements must be kept dry and clean. Remove any acid that has leaked out and spread a little Vaseline on the terminals and then tighten them.

The weight and size of the batteries can affect the stability of the truck, therefore, if a non-standard battery is mounted it is advisable to contact the MANUFACTURERS for the relative authorization.

### Charging the battery

Before beginning to charge, check that the battery temperature is below 30°C and that the electrolyte level is not below the separators (top up with distilled water to the splash guards if this is the case), then check the performance of the conductors.

Connect the battery charger socket (A) to the recharging plug (B) and move the charging unit switch to the ON position. Battery temperature must never exceed 45°C. If this problem occurs, stop charging, let the battery cool down and then restart the charging process at a lower charge current level. When the battery has been charged the battery charger interrupts the supply of current and lights up the STOP led. At this point, switch off (OFF position) and remove the socket (A) from the recharging plug (B) see figure 7. Normal recharging lasts from 14 to 16 hours. When charging is terminated check that all cells have reached a density between 1.270~1.290kg/l at 25°C and the voltage per cell is about 2.7V. It is advisable to recharge the battery after each days work.

**Never completely uncharged the battery and avoid partial charging. Allow the battery charge to signal completion of charging.**

### Substituting the battery

- 1) Remove the battery from its retainers
- 2) Remove the cables from the battery terminals
- 3) Slide out the battery
- 4) Mount the battery following the above instructions in reverse order, fixing it in place and connecting it correctly

**(The battery must always be of the same type that it replaces. After replacing the battery, consign the used one to the nearest petrol station.)**

### Cautions

- 1) Before charging, don't open plugs
- 2) Charge the battery in a well-ventilated place, lifting off the cover or removing the battery from the fork lift

- 3) Never expose the battery to naked flames. Fires may occur from the formation of explosive gas
- 4) Never make temporary or incorrect electrical connections
- 5) Terminal points must be well tightened and free of scale. Cable insulation must be in good condition
- 6) Keep the battery clean, dry and free dust using an antistatic cloth
- 7) Never place tools or other metal objects on the battery
- 8) During recharging, check the temperature of the electrolyte, which must not exceed 45 °C
- 9) Make sure the level of the electrolyte is 15mm above the separators. If the elements are not covered, top up with distilled water. Under normal conditions topping up can be generally done once a week.
- 10) Avoid contact between skin and acid. If skin or clothes come into contact with this acid wash with abundant soap and water.

## Chapter 7 Maintenance

Maintenance must be carried out by specialized personnel.

The truck must undergo a general check up at least once a year.

After every maintenance operation the performance of the truck and its safety devices must be checked.

Inspect the truck periodically so as not to risk the machine stopping or danger for personnel! (see maintenance table)

**Disconnect the master switch before carrying out any maintenance operation.**

**Cleaning:** Clean the parts of the truck, except electrical and electronic elements, with a damp cloth. Do not use direct jets of water, steam or inflammable liquids. Clean electrical and electronic components with dehumidified compressed air at low pressure (max. 5 bar) or with a nonmetallic brush.

MAINTENANCE TABLE

ELEMENT	CHECKS	EVERY		
		3 Months	6 Months	12 Months
STRUCTURE AND FORKS	Check load bearing elements	▲		
	Check nuts and bolts are tightened	▲		
	Check for backstops and play	▲		
BRAKES	Check performance	▲		
	Check lining for wear	▲		
	Check play		▲	
WHEELS	Check wear	▲		
	Check bearing play		▲	
	Check anchorage	▲		
TILLER BAR	Check play		▲	
	Check sideways movement	▲		

	Check return to vertical position		▲	
ELECTRICAL SYSTEM	Check wear of remote control switch	▲		
	Check connections and cable		▲	
	Check master switch	▲		
	Check horn	▲		
	Check dead man's button	▲		
	Check fuse values			▲
HYDRAULIC SYSTEM	Check performance	▲		
	Check oil level		▲	
	Check for leaks and wear of connections	▲		
	Change oil/filter			▲
	Check performance of pressure limiting valve			▲
	Check flow limiting valve			▲
CYLINDER	Check leakage	▲		
	Check wear of gaskets	▲		
MOTORS	Check wear of brushes	▲		
	Check starting motor relay		▲	
BATTERY	Check electrolyte density and level	▲		
	Check voltage of elements	▲		
	Check anchorage and hold of terminals	▲		
	Check cables		▲	
	Check terminals with Vaseline		▲	
INSPECTIONS	Check ascent and descent speed of forks			▲
	Check safety devices	▲		
	Test raising and lowering with nominal load	▲		

### LUBRICATION TABLE

LUBRICATION POINTS	KIND OF LUBRICATOR	EVERY	
		3 Months	6 Months
WHEELS AND ROLLERS	Lithium grease NLG1-2	▲	
LIFTING CHAIN	Lithium grease NLG1-2	▲	
MAST GUIDES	Lithium grease NLG1-2		▲
HYDRAULIC UNIT	Oil viscosity 40°C cSt32		▲

**NOTE: When eliminating used oil please respect the environment. The oil should be stored in a drum that should be later consigned to the nearest petrol station. Do not dump the oil in the ground or in unsuitable places.**

## Chapter 8 Hydraulic diagram

FIGURE8 HYDRAULIC SYSTEM

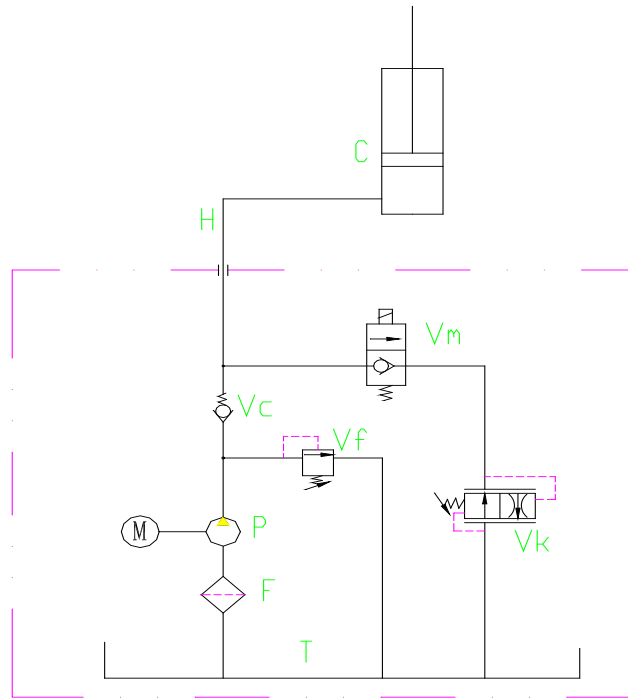

HYDRAULIC ELEMENTS TABLE

Item	Type	Description
1	C	Lifting cylinder
2	H	Hose
3	Vm	Magnet change valve
4	Vc	Check valve
5	Vf	Pressure-limiting valve
6	Vk	Keep speed valve
7	M	Motor pump
8	P	Pump
9	F	Oil filter
10	T	Oil tank

# Chapter 9 Electrical diagram

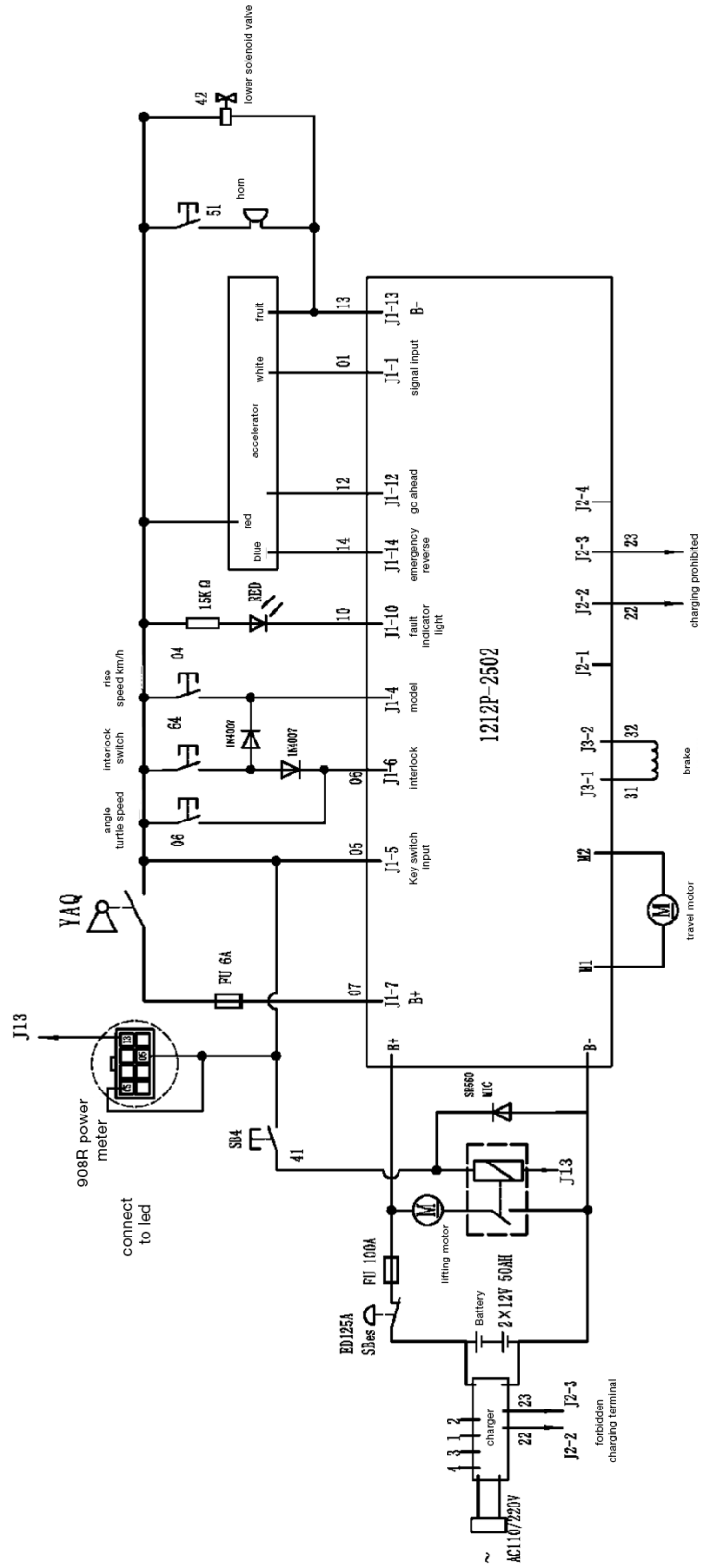



## Chapter 10 Troubleshooting

### The machine doesn't start

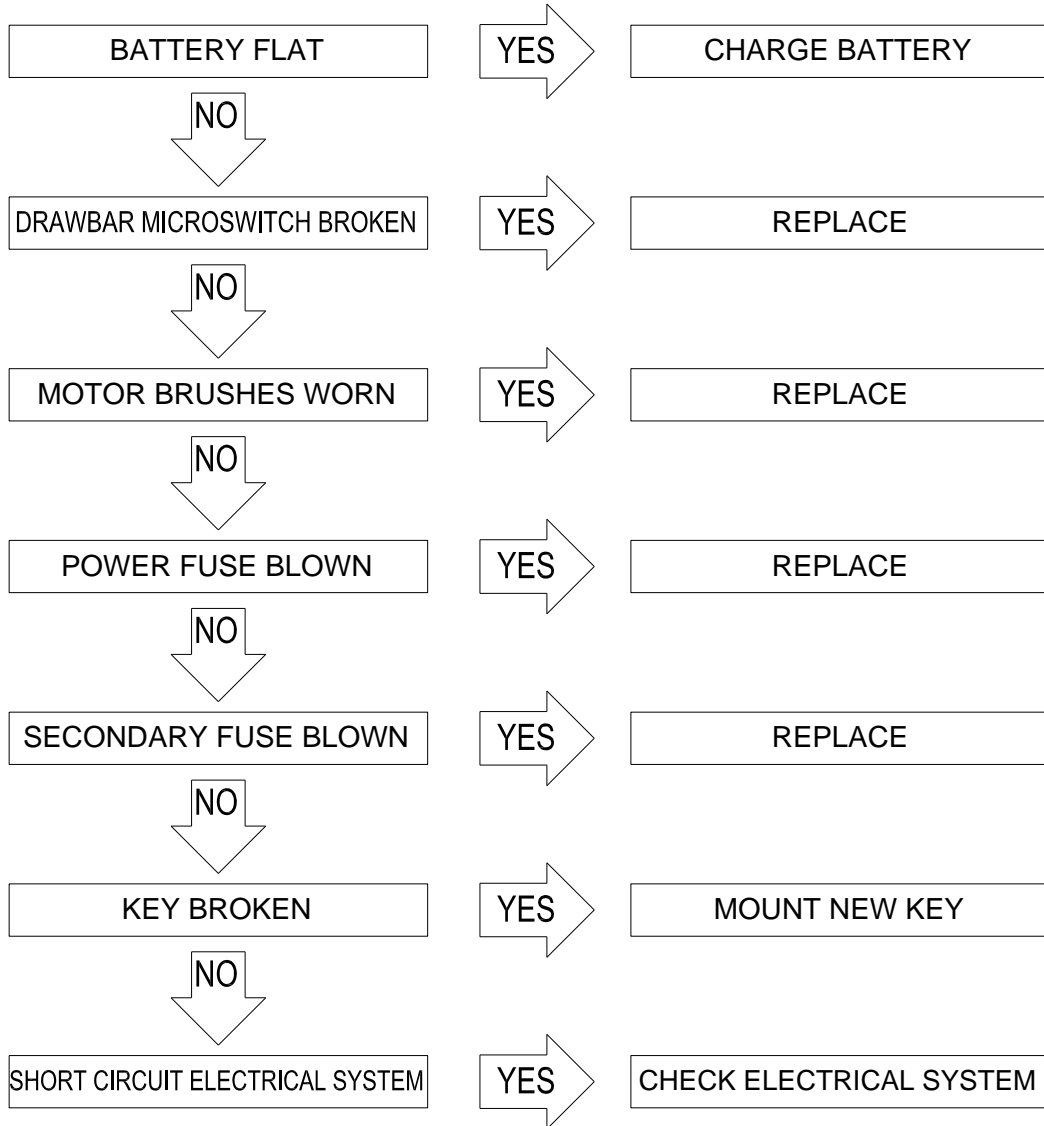

## The carriage won't rise

